



# Vendo V21

# Manual

for

# Pepsi-Cola® High Visibility Identified Equipment



SandenVendo America, Inc.

10710 Sanden Drive • Dallas, Texas 75238 • (800) 344-7216 • (800) 541-5684



# **HIGH VISIBILITY VENDOR PARTS AND SERVICE MANUAL**





## HVV PEPSI TABLE OF CONTENTS

<b>SAFETY SECTION</b> .....	<b>Pages S-1 - S-15</b>
A COMMITMENT TO SAFETY .....	Page S-2
VENDOR INSTALLATION .....	Pages S-3 - S-5
ELECTRICAL HAZARDS .....	Pages S-6 - S-7
MECHANICAL HAZARDS .....	Page S-8
REFRIGERATION HAZARDS .....	Page S-9
TEMPERATURE HAZARDS .....	Page S-9
SUBSTITUTIONS AND MODIFICATIONS .....	Pages S-10 - S-11
CONSUMER SAFETY WARNING .....	Page S-12
PARTS, SALES, AND SERVICE CENTERS .....	Pages S-13 - S-14
<b>GENERAL INFORMATION</b> .....	<b>Pages G-1 – G-12</b>
GENERAL INFORMATION .....	Page G-2
INITIAL SET-UP .....	Pages G-3 - G-4
FLAVOR AND PRICE LABEL INSTALLATION .....	Page G-5
ALIGNMENT CHECKS .....	Page G-6
LOADING INSTRUCTIONS .....	Page G-7
VEND MECHANISM PARTS DESCRIPTION .....	Pages G-8 - G-9
VEND CYCLE .....	Pages G-10 - G-11
<b>PROGRAMMING SECTION</b> .....	<b>Pages PC-1 - PC-14</b>
12.3 CONTROL BOARD OPERATION .....	Pages PC-2 - PC-11
12.3 WIRING DIAGRAMS .....	Pages PC-12 - PC-13
<b>CABINET PARTS SECTION</b> .....	<b>Pages C-1 - C-17</b>
READING A PARTS LIST .....	Pages C-2
HARDWARE LIST .....	Pages C-3 - C-5
CABINET ASSEMBLY .....	Pages C-6 - C-7
STACK ASSEMBLY .....	Pages C-8 - C-9
MECH PLATE ASSEMBLY .....	Pages C-10 - C-11
REFRIGERATION ASSEMBLY .....	Pages C-12 - C-13
POWER BOARD ASSEMBLY .....	Pages C-14 - C-15
HARNESS QUICK REFERENCE GUIDE .....	Page C-16
<b>HVV DOOR PARTS SECTION</b> .....	<b>Pages PD-1 - PD-16</b>
MAIN DOOR .....	Pages PD-2 - PD-5
LIGHTING .....	Pages PD-6 - PD-9
SELECTION PANEL .....	Pages PD-10 - PD-11
T-HANDLE OPTION .....	Pages PD-12 - PD-13
INNER DOOR .....	Pages PD-14 - PD-15
<b>MAINTENANCE</b> .....	<b>Pages M-1 - M-10</b>
PREVENTATIVE MAINTENANCE .....	Page M-2
LUBRICATION GUIDE .....	Page M-2
CARE AND CLEANING .....	Page M-3
REFRIGERATION OPERATION .....	Pages M-4 - M-6
REFRIGERATION PARTS DESCRIPTION .....	Pages M-7 - M-19
<b>TROUBLESHOOTING</b> .....	<b>Page T-1 - T-11</b>
PARTS RETURN PROCEDURES .....	Page T-2
TROUBLESHOOTING GUIDE .....	Pages T-3 - T-10



## **SAFETY SECTION**



## **A COMMITMENT TO SAFETY**

SandenVendo America is committed to safety in every aspect of our product design. SandenVendo America is committed to alerting every user to the possible dangers involved in improper handling or maintenance of our equipment. The servicing of any electrical or mechanical device involves **potential hazards**, both to those servicing the equipment and to users of the equipment. These hazards can arise because of improper maintenance techniques. The purpose of this manual is to alert everyone servicing SandenVendo America equipment of potentially hazardous areas, and to provide **basic safety guidelines** for proper maintenance.

This manual contains various **warnings** that should be carefully read to minimize the risk of personal injury to service personnel. This manual also contains service information to insure that proper methods are followed to avoid damaging the vendor or making it unsafe. It is also important to understand these **warnings** are not exhaustive. SandenVendo America could not possibly know, evaluate, or advise of all of the conceivable ways in which service might be done. Nor can SandenVendo America predict all of the possible hazardous results. The safety precautions outlined in this manual provide the basis for an effective safety program. Use these precautions, along with the service manual, when installing or servicing the vendor.

We strongly recommend a similar commitment to safety by every servicing organization. Only **properly-trained personnel should have access to the interior of the machine**. This will minimize the potential hazards that are inherent in electrical and mechanical devices. SandenVendo America has no control over the machine once it leaves the premises. It is the owner or lessor's responsibility to maintain the vendor in a safe condition. See Section I of this manual for proper installation procedures and refer to the appropriate service manual for recommended maintenance procedures. If you have any questions, please contact the Technical Services Department of the SandenVendo America office nearest you.

## **SAFETY RULES**

- Read the Safety Manual before installation or service.
- Test for proper grounding before installing to reduce the risk of electrical shock and fire.
- Disconnect power cord from wall outlet before servicing or clearing product jams. The vending mechanism can trap and pinch hands.
- Use only fully-trained service technicians for Power-On servicing.
- Remove any product prior to moving a vendor.
- Use adequate equipment when moving a vendor.
- Always wear eye protection, and protect your hands, face, and body when working near the refrigeration system.
- Use only authorized replacement parts.
- Be aware of inherent dangers in rocking or tipping a vending machine.



## SECTION I: VENDOR INSTALLATION

- A. Vendors are large, bulky machines of significant size and weight. Improper handling can result in injury. When moving a vendor, carefully plan the route to be taken and the people and equipment required to accomplish the task safely.
- B. Remove all tape, shipping sealant, and Styrofoam from the vendor. Loosen any shipping devices used to secure interior parts during shipping. Remove the wooden shipping base attached to the vendor base by the vendor leveling screws. Make certain the leveling screws are in place and functional.
- C. Position the vendor three to four inches (7.6 cm to 10.2 cm) from a well-constructed wall (of a building or otherwise) on a flat, smooth surface.

***IMPORTANT:** The vendor requires three inches (7.6 cm) of air space from the wall to ensure proper air circulation to cool the refrigeration unit.*

- D. Adjust the leveling screws to compensate for any irregularities on the floor surface. Ideally, no adjustment will be necessary and the leveling legs will be flush with the bottom of the vendor. A spirit level is a useful aid to level the vendor. When the vendor is properly leveled the outer door, when opened, will remain stationary. Vendors must be level to ensure proper operation and to maintain stability characteristics. Do not add legs to the vendor. **The leveling legs shall not raise the vendor more than 1 1/8 inch above the ground.**
- E. Check the manufacturer's nameplate on the left or right side of the vendor's outer door to verify the main power supply requirements of the vendor. Be sure the main power supply matches the requirements of the vendor. To ensure safe operation, plug the vendor only into a properly grounded outlet.  
**DO NOT USE EXTENSION CORDS.**
- F. Recommended voltage specs = 115V  $\pm$  10%
- G. Dedicated 15A service required for 1 machine.

**NOTE:** Any power supply variance more than  $\pm$  10% may cause the vendor to malfunction.

- \* Power outlets must be properly **grounded**.
- \* Power outlets must be properly **polarized**, where applicable.

Test the outlets using the following information.  
(Refer to Figure 1 on Page S-4.)

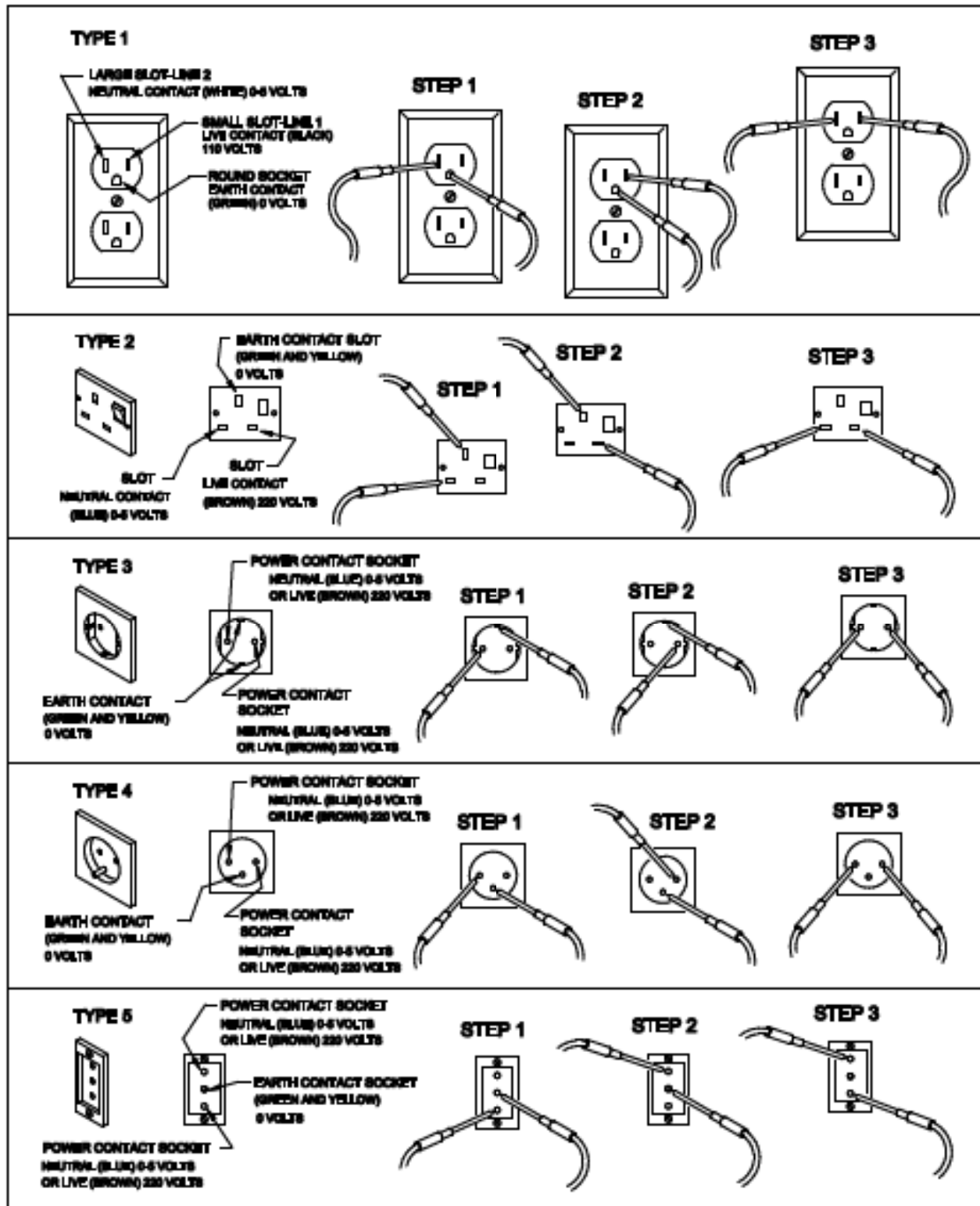





## SECTION I: VENDOR INSTALLATION (CONTINUED)

For Type 1 and Type 2 outlets, test for Grounding and Polarization as follows:

1. With a test device (volt meter or test light), connect one probe to the receptacle's neutral contact and the other to the live contact. The test device should show a reaction.
2. Connect one probe to the receptacle's earth contact and the other to the live contact. The test device should show a reaction.

For Type 3 through Type 5 outlets, test for Grounding as follows:

1. With a test device (volt meter or test light), determine which of the receptacle's power contacts is the live contact.
  - A. Connect one probe to the receptacle's earth contact.
  - B. Connect the second probe to the left (or upper) power contact. If a reaction occurs, this is the live power contact. If a reaction does not occur, move the second probe to the right (or lower) contact. A reaction should occur, indicating that this is the live power contact.
2. Connect one probe to the receptacle's live power contact (as determined in step 1). Connect the second probe to the other power contact (neutral). The test device should show a reaction.

**IF THE ABOVE CONDITIONS ARE NOT MET FOR THE GIVEN OUTLET TYPE, CONTACT A LICENSED ELECTRICIAN AND HAVE THE NECESSARY CORRECTIONS MADE.**

### H. Electronic Power Lock.

The auxiliary, (back-up battery pack), voltage is specified by the lock manufacturer to be 24-30 Volts DC. This is typically provided by a back-up battery pack with (3) 9-volt commercially available alkaline batteries.



## SECTION II: ELECTRICAL HAZARDS

### GENERAL

SandenVendo America vending machines are provided with the appropriate power supply setting for your area. Some models are equipped with step-down transformers, as required. This enables the vending machine to operate on different main voltages. Refer to Section I. E. for information to determine the main power requirements. Refer to the appropriate service manual for details of step-down transformer operations.

The power sources just mentioned are standard for both household and commercial lighting and appliances. However, careless or improper handling of electrical circuits can result in injury or death. Anyone installing, repairing, loading, opening, or otherwise servicing a vending machine should be alerted to this point. Apply all of the normal precautions observed in handling electrical circuits, such as:

- Refrigeration servicing to be performed by qualified personnel only.
- Unplug the vendor or move power switch to off position before servicing or clearing product jams.
- Replace electrical cords if there is any evidence of fraying or other damage.
- Keep all protective covers and ground wires in place.
- Plug equipment into outlets that are properly grounded and polarized (where applicable), and protected with fuses or circuit breakers.
- All electrical connections must be dry and free of moisture before applying power.

### A. Grounding Systems

SandenVendo America vending machines are provided with the appropriate service cord for the power supply in your area. The service cord will connect to the matching electrical outlet. Always ensure that the outlet to be used is properly grounded before plugging in the vendor. (See pages S-3 through S-5.)



The electrical grounding system also includes the bonding of all metal components within the vendor. This involves a system of bonding wires identified by green or green and yellow marking. The system uses serrated head screws, lock washers, and star washers to ensure the electrical connection between parts. Maintenance of vending equipment may involve disassembly. Include the above items when reassembling, even if the vending machine may appear to function normally without them. Omitting any of these items can compromise a link in the grounding system. See the appropriate service manual or kit instructions for components and assembly instructions.

## SECTION II: ELECTRICAL HAZARDS (CONTINUED)

### B. Servicing with “Power Off”

For maximum safety, unplug the service cord from the wall outlet before opening the vendor door. This will remove power from the equipment and avoid electrical and mechanical hazards. Service personnel should remain aware of possible hazards from hot components even though electrical power is off. See the appropriate sections of this manual for further information.

### C. Servicing with “Power On”

Some service situations may require access with the power on. Power on servicing should be performed **only by fully-qualified service technicians**. Particular caution is required in servicing assemblies that combine electrical power and mechanical movement. Sudden movement (to escape mechanical action) can result in contact with live circuits and vice versa. It is therefore doubly important to maintain maximum clearances from both moving parts and live circuits when servicing.



Power to lighting and refrigeration system is shut off automatically by the electronic controller when the outer door is opened.

**NOTE:** For power-on servicing of the vendor’s lighting system, turn lighting power on by accessing the Lights test function of the electronic controller (see programming on inner door).

For power-on servicing of the vendor’s refrigeration system, turn refrigeration power on by accessing the Compressor test function of the electronic controller (see programming on inner door).

### SECTION III: MECHANICAL HAZARDS

#### A. Servicing of Moving Parts and Assemblies

When servicing assemblies involving moving parts, **use extreme caution!!** Keep fingers, hands, loose clothing, hair, tools, or any foreign material clear of entrapment.

As noted before under the electrical hazards section, Power On servicing should **only** be performed by qualified personnel. Refer to and heed the warnings noted in the electrical hazards section. These warnings refer to the potential hazards associated with electrical power and moving parts. Always maintain maximum clearances from electrical and moving parts.

Always install protective covers and guards when reassembling equipment.

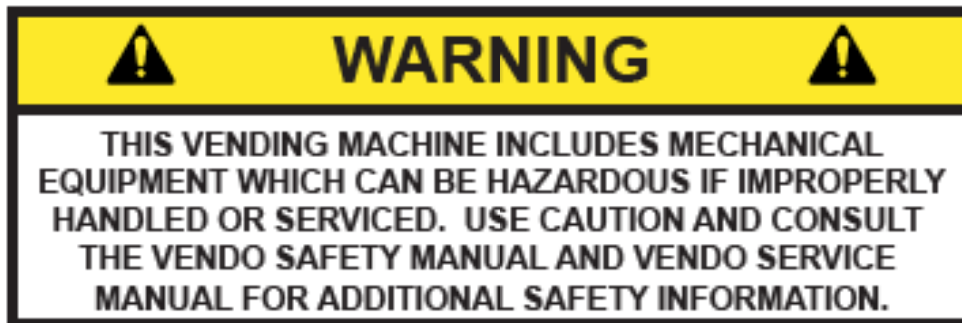



## SECTION IV: REFRIGERATION HAZARDS

### GENERAL

Refrigeration systems involve both electrical power and mechanical action. These systems may present any of the potential dangers shown in the sections on electrical and mechanical hazards contained in this manual. See Sections II and III for further information.

#### A. Compressed Refrigerant

Refrigeration systems involve the compression and evaporation of gases. The contained pressures represent a potential hazard if suddenly released in confined areas. Caution is required when performing maintenance tests or repairs. All testing of sealed refrigeration systems must be done by trained personnel who are familiar with the systems and pressures involved.

#### B. Physical Protection

The accidental release of refrigerant gases can result in physical injuries. Always wear protective glasses and protect your hands, face, and body when working near the refrigeration system.



## SECTION V: TEMPERATURE HAZARDS

### GENERAL

Maintenance personnel should be alerted to the potential hazards from hot metal surfaces. High temperatures may be present throughout the refrigeration system even though electrical power has been removed.



## SECTION VI: SUBSTITUTIONS AND MODIFICATIONS

### GENERAL

Unauthorized changes or the substitution of unauthorized parts can compromise the equipment designs. This can result in unsafe conditions for either the service personnel or the equipment users. Always refer to the appropriate parts and service manual for replacement parts and maintenance instructions. If questions arise, contact the Technical Services Department of the SandenVendo America office in your area.

When servicing the vending machine, always reassemble all components to their original location and position. Maintain the correct routing for tubing, electrical wiring, etc. Replace all clamps, brackets, and guides to their original locations. Replace all tubing, sleeving, insulating material, and protective covers to their original condition.

 <b>WARNING</b> 
<b>SANDENVENDO AMERICA EQUIPMENT HAS BEEN PROVIDED WITH APPROPRIATE PROTECTIVE DEVICES TO PROTECT AGAINST THE POSSIBILITY OF OVERHEATING AND FIRE AS A RESULT OF EQUIPMENT OR COMPONENT FAILURES. SUBSTITUTION, MODIFICATION, OR BYPASSING OF SUCH PROTECTIVE DEVICES CAN CREATE DANGEROUS CONDITIONS. PROTECTIVE CIRCUITS SHOULD NEVER BE BYPASSED, AND FAILED PROTECTIVE DEVICES MUST BE REPLACED ONLY WITH FACTORY-AUTHORIZED PARTS.</b>

#### A. Service Cord Replacement

SandenVendo America vending machines are furnished with unique power supply cords. If replacement becomes necessary, consult the appropriate parts and service manual and order the correct replacement cord for the model of vending machine in question. Do not use substitute replacement cords. Only authorized service personnel with appropriate training should replace the vending machine service cord. If a question should arise concerning which service cord to order, contact the Technical Services Department of the SandenVendo America office in your area.



**SECTION VI: SUBSTITUTIONS AND MODIFICATIONS (CONTINUED)**



The wires in the main leads are colored in accordance with the following code:

<b>110v/120v</b>	<b>220v/240v</b>	
Green	Green and Yellow.....	Earth
White	Blue.....	Neutral
Black	Brown.....	Live



## SECTION VII: CONSUMER SAFETY WARNING



### GENERAL

There have been incidents, including fatalities, when vending machines have been vandalized by being pulled over in an attempt to obtain free product or money.

To warn of the danger involved in tipping, shaking, or rocking the vending machine, a decal has been designed to be affixed to vending machines. (One such decal is applied on the vending machine.) SandenVendo America will supply sufficient decals to be placed on all machines, on request. If you have any questions, contact the Technical Services Department of the SandenVendo America office in your area.

**THE FOLLOWING DECAL SHOULD BE PLACED IN A POSITION ON THE VENDOR CONTROL PANEL AT EYE LEVEL**



ENGLISH



FRENCH

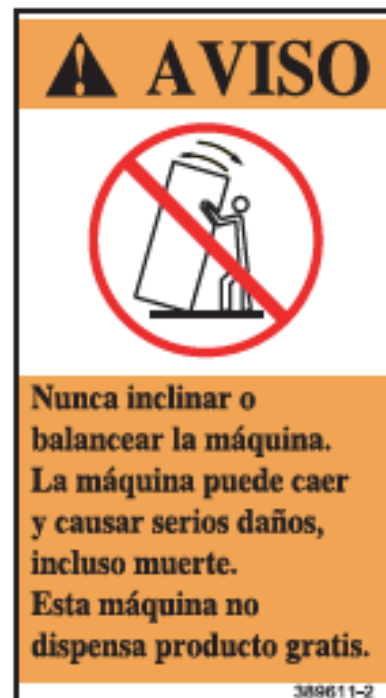

SPANISH





## PARTS, SALES, & SERVICE CENTERS OF SANDEN COMPANY

AREA	ADDRESS	PHONE NUMBERS
United States, Canada	SandenVendo America, Inc. 10710 Sanden Drive Dallas, TX 75238-1335 U.S.A.	Tel: (800) 344-7216 ext. 3368 Fax: (800) 541-5684
Japan	Sanden International Corporation 31-7 Taito 1-Chome Taito-ku Tokyo 110, Japan	Tel: (81) 3-3835-1321 Fax: (81) 3-3833-7096
Europe, Mid-East Africa, Mid-Asia	Vendo GMBH Spangerstr. 22, P.O. Box 130940 40599 Dusseldorf Germany	Tel: (49) 211-74-039-0 Fax: (49) 211-7488541
Australia, New Zealand	Sanden International Pty. Ltd. 54 Allingham St., Condell Park N.S.W. 2200 Australia	Tel: 61-2-9791-0999 Fax: 61-2-9791-9029
Singapore, Hong Kong, Indonesia, Phillippines, India	Sanden International (Singapore) Pte., Ltd. Sanden House, 25, Ang Mo Kio St. 65 Singapore 569062 The Republic of Singapore	Tel: 65-482-5500 Fax: 65-482-1697
Taiwan	Sanden International Taiwan Corp. No. 21-6, Sec 1 Tun Hwa S. Rd., Taipei, Taiwan Taiwan, ROC	Tel: 886-2-570-6106 Fax: 886-2-577-1959
Belgium	N.V. Vendo Benelux, S.A. Industrial Research Park N.O.H. 13 Font St. Landry 1120 Brussels Belgium	Tel: 32-2-268-2595 Fax: 32-2-268-2862
England	Vendo UK Ltd. Vendo House Kingsclere Road Basingstoke, Hants RG21, 5GU Great Britain	Tel: 44-1256-479309 Fax: 44-1256-844469
Italy	Vendo Italy S.p.A. Casella Postale 9 1-15033 Casale Monferrato Italy	Tel: 39-142-335111 Fax: 39-142-5623-48
Spain	Vendo Iberia, S.A. C/ Sant Ferran No. 92 Poligono Industrial la Almeda, Sector P-1 08940 Cornellà, (Barcelona), Spain	Tel: 343-474-1555 Fax: 343-474-1842



**PARTS, SALES, & SERVICE CENTERS OF SANDEN COMPANY  
FOR LATIN AMERICA**

AREA	ADDRESS	PHONE NUMBERS
Mexico	Vendo de Mexico Carreta Mexico - Tequisquiapan Km 3.2 San Juan del Rio, Queretaro C.P. 76800	Tel: (52) 427 2718096 Fax: (52) 427 2718077
Mexico	IMI Cornelius de Mexico, S.A. de C.V. Manual Dublan No. 35 Col. Tacubaya, Deleg. Miguel Hidalgo C.P. 11870 Mexico	Tel: (52 55) 5272-7904 Fax: (52 55) 5273-5949
Central America	SandenVendo America, Inc. 10710 Sanden Drive Dallas, TX 75238-1335 U.S.A.	Tel: (214) 765-9066 Fax: (214) 221-7010
South America	SandenVendo America, Inc. 10710 Sanden Drive Dallas, TX 75238-1335 U.S.A.	Tel: (214) 765-9066 Fax: (214) 221-7010



NOTES



**GENERAL INFORMATION  
SECTION**



## GENERAL INFORMATION

This manual contains programming, operation, and complete parts and electrical wiring diagrams.

The V21 controller is a microprocessor which will permit pricing per selection from 0.00 to 99.99. This machine also has space-to-sales programming as well as energy savings modes.

MODEL		V21 721	V21 821	V21 621
SELECTIONS		12	12	6
DIMENSIONS (HEIGHT X WIDTH X DEPTH)				
HIGH VISIBILITY DOOR		72" x 39 1/2" x 34 3/4"	78" x 39 1/2" x 34 3/4"	72" x 32 1/2" x 34 3/4"
SINGLE COLUMNS		10	10	8
CAPACITY PER COLUMN	12 oz. CAN***	68	80	68
	16 oz. GLASS	28	34	28
	20 oz. **	30	36	30
SHIPPING WEIGHT		685 lbs	750 lbs	611 lbs
OPERATION VOTAGE		115V 60Hz.	115V 60Hz.	115V 60Hz.
AMP. RATING		8	8	8
REFRIGERATION VOLTAGE		115V 60Hz.	115V 60Hz.	115V 60Hz.

\*Dimensions and shipping weight will vary slightly due to manufacturing tolerances, shipping boards and whether or not coinage is installed.

\*\* 20 oz. PET capacity may vary based on the shape and size of the bottle.

\*\*\*12 oz. can capacities are listed using a 4-deep set up.



## INITIAL SET-UP

### A. UNPACKING

Remove all plastic film, cardboard and tape from the outside of the vendor. Loosen any shipping devices used to secure interior parts during shipment (backspacer, shims or spacers).

To remove shipping boards from base, raise vendor on a well-stabilized lifting device. Remove the leveling bolts which hold the boards in place and remove the boards. Replace bolts to equal heights in the threaded holes. Another method to remove shipping boards is to split the boards apart. Using a pinch bar or a heavy screwdriver and hammer, insert tool into the slots and force the boards apart. **The leveling legs shall not raise the vendor more than 1 1/8 inch above the ground.**

### B. POSITIONING

**IMPORTANT: PLACE THE VENDOR IN DESIRED LOCATION AT LEAST THREE TO FOUR INCHES (7.6CM TO 10.2CM) AWAY FROM ANY REAR OBSTRUCTION.** This is for proper air flow through the refrigeration compartment. The refrigeration system requires rear to front air circulation for proper operation.

### C. POWER SUPPLY CONNECTION

#### **CAUTION: DO NOT USE AN EXTENSION CORD!**

The vendor's power requirements will vary depending upon the country it was purchased for. To verify the power requirements of the vendor, check the serial plate located on the hinged side of the outer door (see Figure 4 on page G-4). The power requirements are listed on the serial plate.

To insure safe operation of the vendor, the vendor's power supply must be a properly grounded and polarized outlet. Before plugging the vendor into the outlet, test the outlet to confirm it will meet the vendor's power requirements. If the power supply of the outlet is different from the power requirements of the vendor, a transformer may be necessary.

If the power requirements are not properly met, contact a licensed electrician and have the necessary correction made.

Should you require additional information, contact the Technical Services Department of the SandenVendo America office in your area.

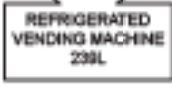

APPROVED FOR OUTDOOR USE

MODEL	<input type="text"/>	BASIC UNIT	<input type="text"/>
SERIAL NO.	<input type="text"/>		
<input type="radio"/> CHARGE	<input type="text"/>	OZ. R-134a	<input type="text"/> AMPS
DESIGN PRESSURE - PSIG LOW SIDE 90 HIGH SIDE 295			<input type="text"/> VOLTS
			<input type="text"/> CYCLE
			<input type="text"/> PHASE

 MFD IN U.S.A. BY SANDENVENDO AMERICA, INC., DALLAS, TX

POWER REQUIREMENTS 

FIGURE 1

**NOTE:** The Model number of the vending machine is located on the top, left hand corner of the serial plate. **Do Not use the "BASIC UNIT" number.** The BASIC UNIT number is the cabinet size, which is used on a number of different machines. A typical model number could read "721TDD00029". The 721 is the model number, TDD represents the product line of the vendor, and the remaining digits tell what options are included.

## LABEL INSTALLATION

### A. FLAVOR LABELS

Before installing flavor labels, bend the top (removal) tab down. To install flavor labels, insert the two small tabs on the bottom edge of the label into the slots in the selection button. Press the label in near the two upper tabs until the tabs snap into the slots in the upper wall of the selection button. (See Figure 2.)

**Note:** If vendor is equipped with optional sold out/ready to vend indicators, then remove the perforated slug from the lower corner of the flavor label to allow the LED dome to show through. (See Figure 2.)

### B. PRICE LABELS

Individual price labels can be applied to the flavor labels. The price labels are located in the upper right corner of the flavor labels in the area indicated by a dashed oval.

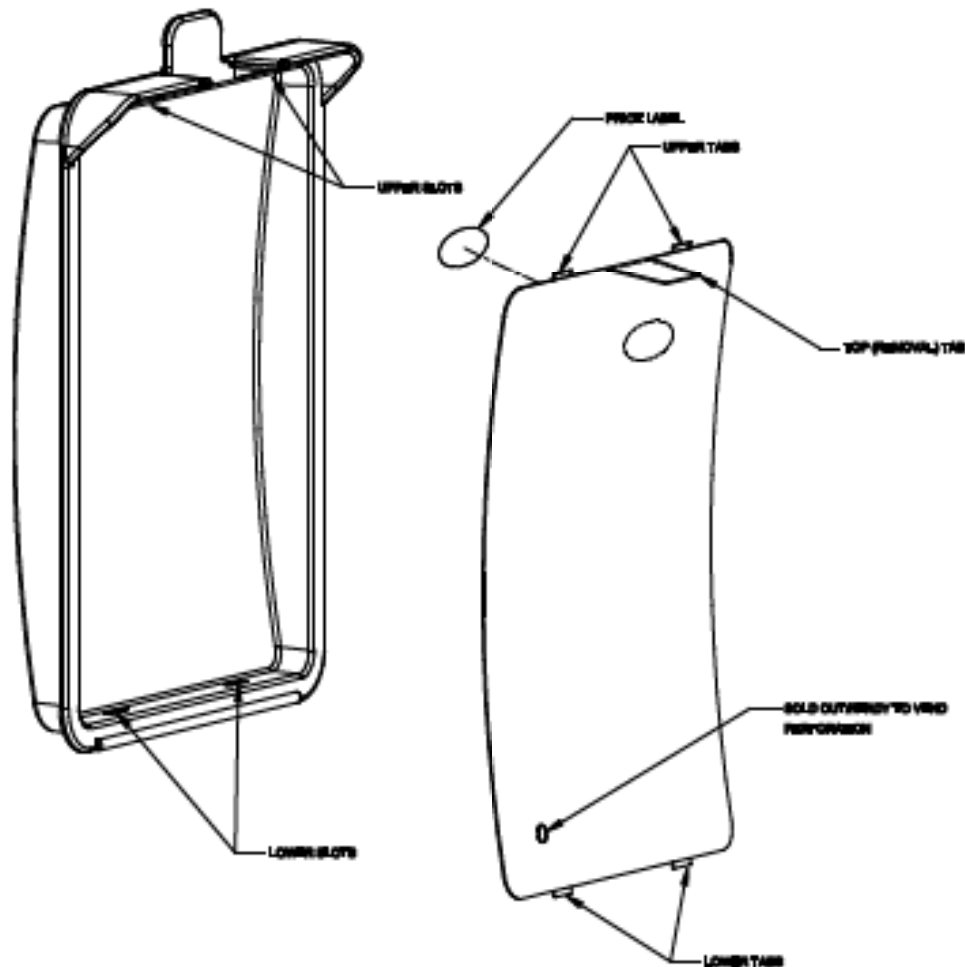
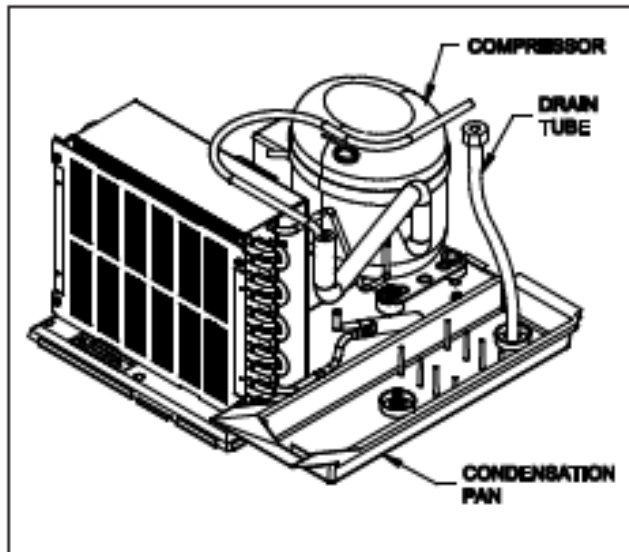

FIGURE 2





## ALIGNMENT CHECKS

### REFRIGERATION AREA CHECK:

Check the position of the condensation pan (see Figure 5). The correct position of the pan is on the right hand side of the vendor with the ramp of the pan just outside the right hand air dam. Be sure the drain tube is attached to the pan and is free of kinks. A water trap is installed into the condensation pan and will prevent warm, moist air from reaching the evaporator area.

## LOADING INSTRUCTIONS

### BASIC LOAD SET-UP:

The V21 machine is capable of vending a variety of products. For specific information, refer to the product set-up label on the machine inner door or contact the Technical Services Department of the SandenVendo America office in your area.

Load product evenly. Product is to be loaded differently depending on the type of product being vended. Use the directions in Figure 4 in the PRODUCT LOADING section to determine how to load a specific product.

To maintain the integrity of the stack, never move a vending machine when it is loaded.

## V21 PRODUCT SETUP AND LOADING INSTRUCTIONS

FOLLOW THE 3 STEPS BELOW WHEN SETTING VENDOR UP FOR A PRODUCT

- 1** **BACK SPACER**  
Adjust the back spacer to provide approx. 1/4" to 1/2" gap between the front spacer, product and back spacer.

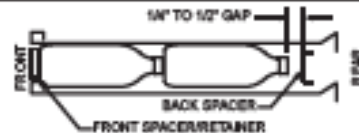

- 2** **PRODUCT STEP**  
For short product vending, move the product step to the "FORWARD" position.  
For tall product vending, move the product step to the "BACK" position.

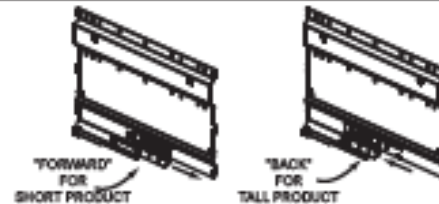

- 3** **DEPTH SETTING (ELECTRONIC CONTROL MODE)**  
The "DEPTH SETTING" for each column must correspond to the number of products in the column. For example; the depth setting for a column vending double depth bottles must be set to "2", and a column set to vend quadruple depth cans must be set to "4". Refer to the VEC 12 programming instructions for details on how to access and change the depth setting mode.

- 4 Deep: Cans between 4.50" and 4.85" tall.
- 3 Deep: Bottles or cans between 4.85" and 6.50" tall.
- 2 Deep: Bottles between 6.50" and 9.95" tall.
- 1 Deep: Bottles taller than 9.95".



### PRODUCT LOADING

- Single depth bottles should be loaded with cap toward the back.
- Double depth bottles may be loaded with caps toward the back, or butt to butt.
- Triple depth bottles must be loaded with caps toward the back.
- Quadruple depth cans may be loaded any direction.

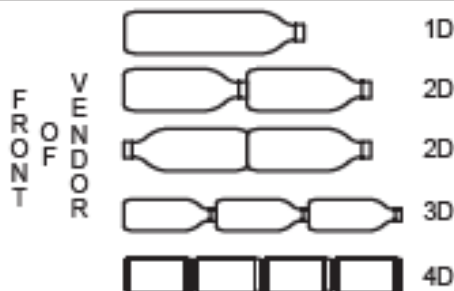

### SMALL DIAMETER PRODUCT SETTING

- Small diameter products (less than 2.5"  $\varnothing$ ) such as 500 ML water bottles require the use of side spacer PN 1125021.



- Small diameter 250 ML energy drink cans (2.1"  $\varnothing$ ) require the use of conversion kit PN 1121638.



### NOTES

- Side spacers **ARE NOT** required for 12 oz. can vending.
- Vend mechanism is self priming. No need to manually prime after initial load or reload.
- For questions regarding product settings, contact the Vendo Technical Services Department at 1-800-344-7216 ext.3388 (US/Canada) or 559-439-1770 ext.3368.

1126121

FIGURE 4



## VEND MECHANISM PARTS DESCRIPTION

The parts listed below are part of the vend motor mechanism (refer to Figure 5 on page G-9). One mechanism is required per column, except for the drop sensor assembly. The parts are interchangeable. Setting will differ between single, double, triple, and quadruple depth.

### **VEND MOTOR ASSEMBLY: P/N 1122820**

The motor is attached to the mech plate by two screws.

### **VEND BUCKET: P/N 1122815**

The vend bucket holds the product(s) in a "ready to vend" position at the base of each column.

### **MOTOR COUPLING CAM: P/N 1122817**

The coupling cam couples the motor to the bucket. It is located behind the motor, on the motor shaft. It is also a means to provide feedback to the controller to determine when the motor has reached maximum clockwise and counterclockwise positions.

### **GATE: P/N 1122818**

The gate holds product above the vend bucket.

### **GATE LINK: P/N 1122819**

The rotation of the coupling cam moves the gate link. This opens the gate, allowing one layer of product to drop into the bucket.

### **CAN STEP: P/N 1122856**

The can step is located at the bottom of the stack partition. It is pulled forward when vending cans and is moved back for bottle vending.

### **REAR BUSHING: P/N 1122816**

The rear bushing provides a low friction pivot for the rear of the bucket.

### **FRONT SPACER: P/N 1122814**

The front spacer helps to guide product into the bucket.

### **DROP SENSOR ASSEMBLY: P/N 1122923**

The drop sensor assembly is located below the delivery chute. When a product is vended, the drop sensor senses the impact, and cancels the credit.

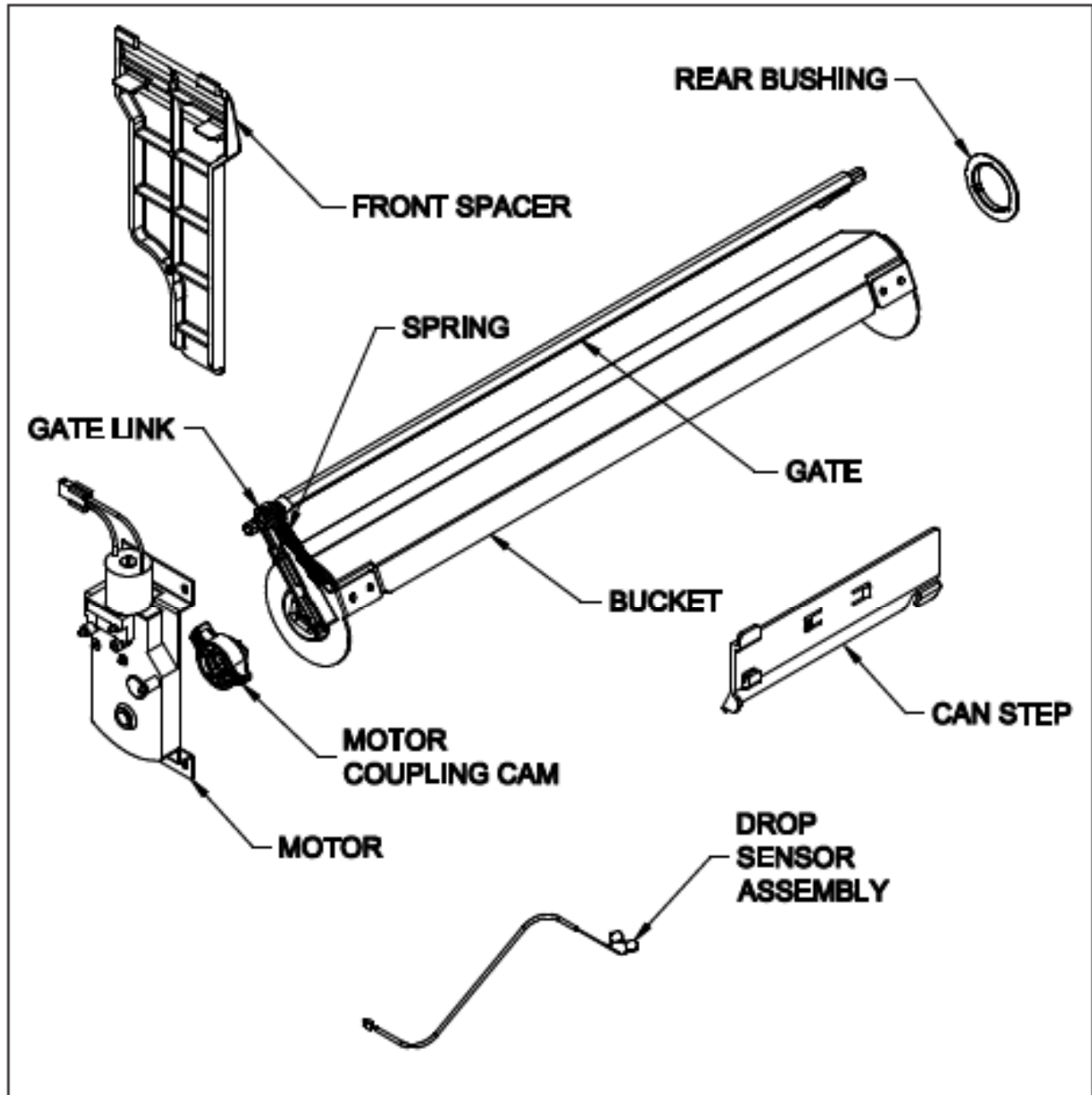

FIGURE 5

## VEND CYCLE

Several operations take place during the vend cycle: When a selection is made, the coupler and bucket rotate, product is dispensed and the bucket is then reloaded. The sequence of these operations change slightly when the column's depth setting is changed. With the single depth setting, one purchase is made and the bucket is reloaded. With the double depth setting, two purchases are made before the bucket is reloaded. With the triple depth setting, three purchases are made before the bucket is reloaded. With the quadruple depth setting, four purchases are made before the bucket is reloaded. (See Figures 6 & 7)

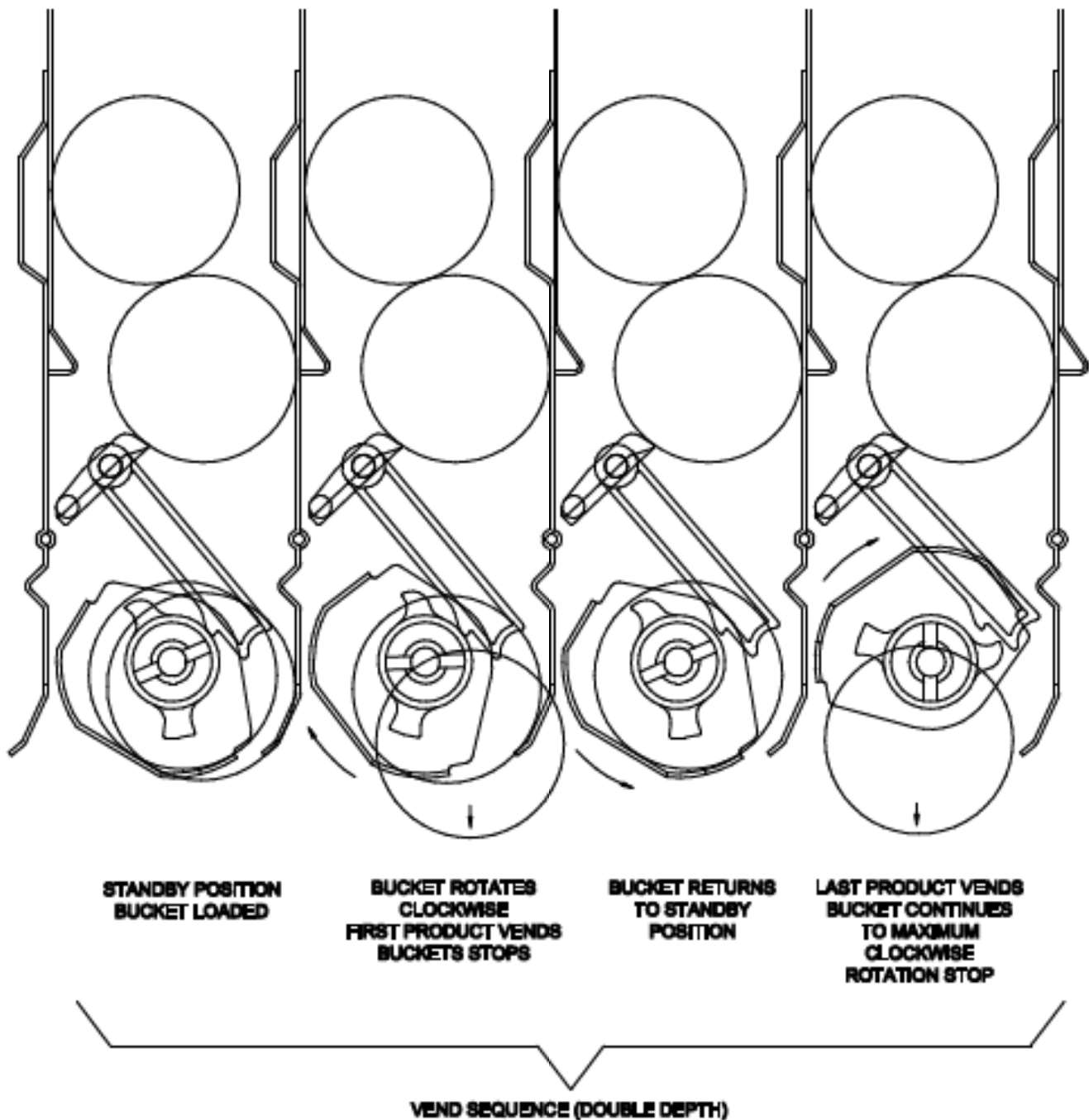
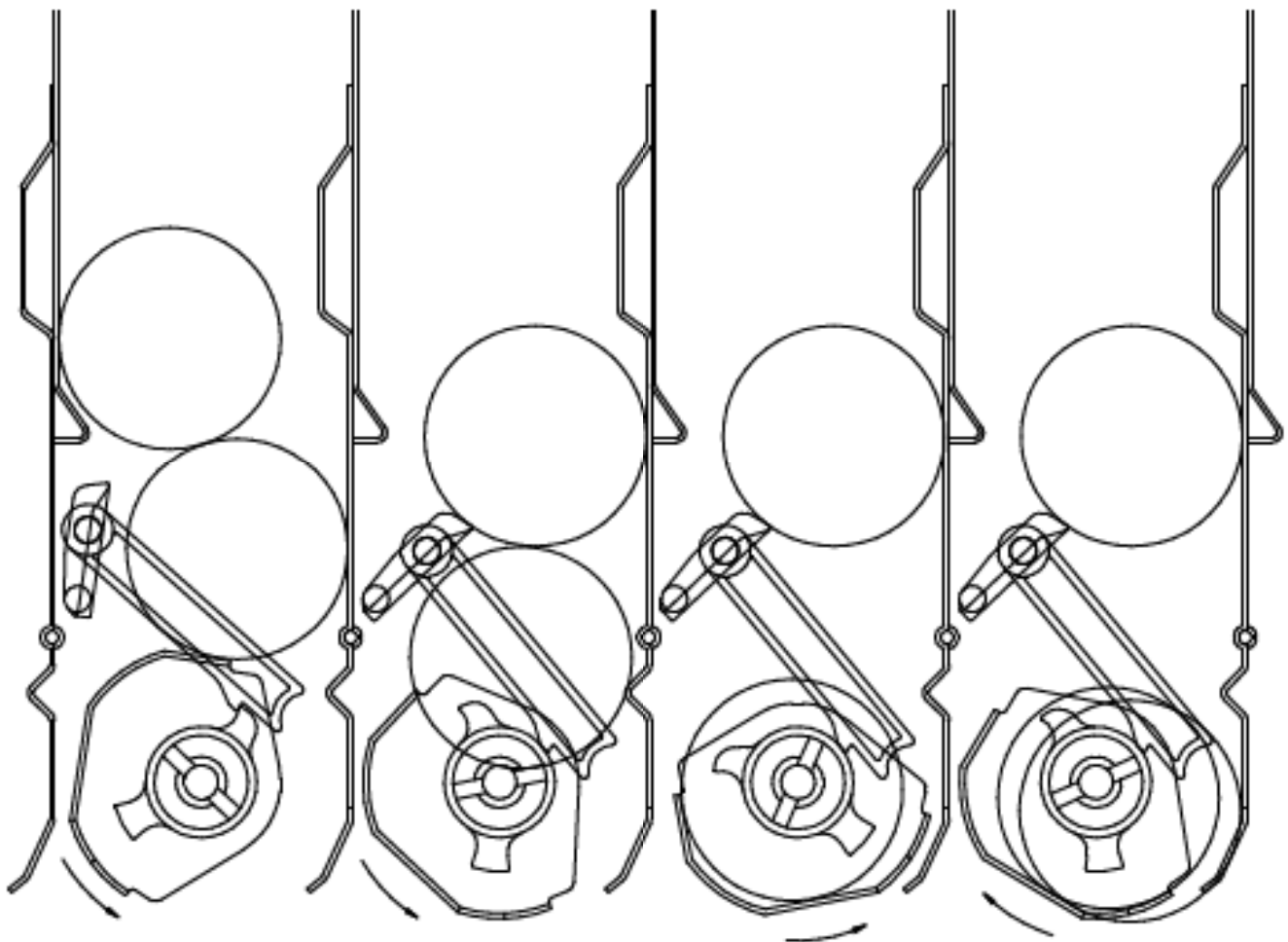

FIGURE 6



**BUCKET ROTATES  
COUNTERCLOCKWISE  
CAM PUSHES LINK  
LINK OPENS GATE**

**BUCKET CONTINUES  
COUNTERCLOCKWISE  
GATE CLOSSES AS  
PRODUCT LOWERS  
INTO BUCKET**

**BUCKET REACHES  
MAXIMUM  
COUNTERCLOCKWISE  
ROTATION STOP**

**BUCKET ROTATES  
CLOCKWISE UNTIL IT  
REACHES STANDBY  
POSITION**

**RELOAD SEQUENCE**

**FIGURE 7**



NOTES



## **12.3 PROGRAMMING SECTION**





## VEC 12.3 Control Board Operation

**NOTE:** Some units may contain a european font display, in which case the “°” symbol will be replaced by the “B” symbol. Example: 72°F will be 72 B F.

The VEC 12.3 controller operates via a 3-button programming system:

- Row 1 (all selection buttons in top row) – Increase/Decrease
- Row 2 (all selection buttons in middle row) – Enter and/or Save
- Row 3 (all selection buttons in bottom row) – Escape/Exit

In order to access the mode functions, open the inner door. Locate the mode button. Press the mode button one time. Row 1 will take you through the modes.

The available modes are:

*Diagnostics*  
*Coin Payout*  
*Tube Fill*  
*Test Mode*  
*Cash Data*  
*Sales Data*  
*Set Price*  
*Set Depth*  
*Configuration*  
*Space to Sales*  
*Door Closed Password*  
*Set Language*  
*Set Clock \**  
*Lighting \**  
*Refrigeration\*\**  
*Sales Block 1 \**  
*Sales Block 2 \**  
*Discount \**  
*Override \*\**  
*Return*

\* These modes will only appear when the *Timing Features* in *Configuration* are turned ON.

\*\* Limited options will appear in these modes depending on whether the *Timing Features* are ON/OFF.



## ***Diagnostics***

See inner door of vendor or Trouble Shooting section for errors and how to clear them.

### ***Coin Payout***

Allows you to payout coin tubes.

- Press (2) to enter into *Coin Payout* mode.
- Press (1) to choose denomination.
- Press (2) to dispense displayed denomination.
- Press (3) to exit mode.

### ***Tube Fill***

Allows you to fill coin tubes via external coin insert. This is the recommended way to fill the coin tubes because the control board is able to keep an accurate count of the coins.

- Press (2) to enter into *Tube Fill* mode.
- Insert coins into coin insert slot and the controller will "count" the number of coins going into the coin mechanism.

### ***Test Mode***

Allows you to test vend a column, jog a column, test selection switches, display, refrigeration system, lights, and heater.

#### ***Vend Testing***

- At *Test Mode*, press (2)
- Display will read column X
- Press (1) to choose desired column
- Press (2) to vend
  - If motor vends OK, DISPLAY will read "*Test Mode - Vending Motor OK*"
  - If motor does not test OK one of the following messages will appear:
    - "*Test Mode - Vending Fail -Column Jam*"
    - "*Test Mode - Vending Fail -No Connection*"
    - "*Test Mode - Vending Fail -High Current*"

#### ***Jogging a Column***

- At *Test Mode*, press (2)
- At *Test Mode - Vending*, press (1)
- Display will read *Test Mode – Jog*
- Press (2) and display will read *Column 1*
- Press (1) to choose desired column
- Press (2) to enter into column and display will read *Column X Forward* with X being the desired column.
- Press (1) to toggle between *Forward* or *Reverse*
- Press (2) to move/jog the motor in the desired position
- Press (3) to exit this mode



### Selection Switch Testing

- At *Test Mode*, press (2)
- At *Test Mode – Jog*, press (1)
- *Test Mode Switches* will be displayed. Press (2).
- Press desired selection switch to be tested.
- To exit, press (3) and hold for 3 seconds.

### Test Mode – Display

Allows you to verify that all of the characters on the display illuminate.

- At *Test Mode*, press (2)
- Press (1) until the display reads *Test Mode – Display*
- Press (2)
- All of the characters on the display should illuminate.
- To exit, press (3)

### Test Mode - Relays

Allows you to test the compressor, evaporator fan, lights and heater

- At *Test mode*, press (2)
- Press (1) until display reads *Test Mode - Relays*
- Press (2)
- To advance through sub-modes, press (1)
- To test compressor, press (2) at *Compressor* prompt
- To test evaporator fan, press (2) at *Fan* prompt
- To test lighting system, press (2) at *Light* prompt
- To test optional heater, press (2) at *Heater* prompt
- To exit sub-modes, press (3)

### Cash Data

Allows you to retrieve historical information regarding the money accepted by the vendor. To clear the individual selection cash data, you must have the *MIS Auto Reset* in the *Configuration* mode turned ON.

- Press (2) when the display reads *Cash Data*.
- The non-resettable historical data is displayed.
- To display resettable individual selections, press (1)
- To reset historical data, make sure the *MIS Auto Reset* is turned ON in the configuration mode.
- To exit mode, press (3)



## **Sales Data**

Allows you to retrieve historical information regarding the number of units sold by the vendor. To clear the individual selection sales data, you must have the *MIS Auto Reset* in the *Configuration* mode turned ON.

- Press (2) when the display reads *Sales Data*.
- The non-resettable historical data is displayed.
- To display resettable individual selections, press (1)
- To reset historical data, make sure the *MIS data reset* is turned ON in the *Configuration* mode.
- To exit mode, press (3)

## **Set Price**

Allows you to set the vend price of each selection. In this mode, you have the option of pricing each selection button at the same vend price or price each selection button independently.

- Press (2) when display reads *Set Price*
- Pressing (1) will allow you to choose selections or *ALL*
- Pressing (2) will start the current vend price flashing
- Press (1) to increase/decrease the price
- Press (2) to save your new programmed price
- Press (3) to exit mode

## **Set Depth**

Allows you to set the depth of each column. In this mode, you have the option of setting the columns for single, double, triple or quadruple depths.

- Press (2) when the display reads *Set Depth*
- Pressing (1) will allow you to choose columns or *ALL*
- Pressing (2) will enter you into the column and start the depth flashing
- Press (1) to scroll through the depth settings (1-4)
- Press (2) to save your new depth setting
- Press (3) to exit mode



## **Configuration**

There are various options that you can turn ON/OFF. The options are:

### *Multi-Price*

ON = All selections can be programmed individually.

OFF = All selections will be set to the same price as selection 1.

### *Timing Features\**

ON = Gives you access to the *Clock* settings and its associated modes.

OFF = *Clock* settings and its associated modes are hidden.

### *Door Summary*

ON = Sales and cash data are displayed as soon as the outer door is opened or by activating the door switch.

OFF = Sales and cash data are not displayed when the door is opened.

### *MIS Auto Reset*

ON = Resets if the counter is checked and after the door is closed

OFF = Does not reset

### *Consumer Overpay*

ON = A dollar bill will be accepted even if the correct change light is on and there is insufficient change in the coin tubes.

OFF = A vend will not be allowed when the correct change light is on and the consumer attempts to use the dollar bill validator.

### *Save Credit Timer*

ON = Credit that is established will be displayed for five minutes unless someone either makes a vend or presses the coin return button – whichever comes first.

OFF = Credit that is established will remain indefinitely unless someone either makes a vend or presses the coin return button.

### *Force Vend*

ON = The consumer will not be able to insert a dollar into the validator, hit the coin return and receive change without first attempting a vend.

OFF = The consumer can insert a bill into the validator, press the coin return button and immediately receive change.

### *Multi-Vend*

ON = The consumer may insert enough credit to make multiple vends. The credit will remain on the display until an additional vend is made or the coin return button is pressed.

OFF = The consumer is allowed to make a single vend and the credit (if applicable), will be returned after the completion of the vend.



### *Deny Escrow*

ON = The validator will stack all bills received.

OFF = The validator will not stack the bills, rather it will hold them in escrow until a vend is complete.

### *SO Indicator*

ON = A small symbol will appear in the lower right hand corner of the display when at least one column is sold out or the machine detects an error.

OFF = The symbol will not appear.

### *Count by Selection/Price*

COUNT BY SELECTION = Individual sales and cash data will be reported in unit sales.

COUNT BY PRICE = Individual sales and cash data will be reported by vend price.

### *MIS Reset W/ DEX*

ON = MIS data will be reset with a DEX read.

OFF = MIS data will not be reset with a DEX read.

### *Depth Learning*

ON = The control board will "learn" the depth setting after one row of product in the column is vended

OFF = The control board will not "learn" the depth setting

### *# of Selections 6/12*

Number of Selections: 6 = 6 select vendor

Number of Selections: 12 = 12 select vendor

- To adjust any of the settings, press (2) at *Configuration* mode.
- Press (1) to scroll through the modes.
- Press (2) to change the mode. The current setting will begin to flash.
- Press (1) to change current setting.
- Press (2) to save change.
- Press (3) to exit sub-mode.

### ***Space to Sales***

Allows you to program which column will vend when you choose a desired selection button. There are 6 preset configurations (See inner door label for preset options). You also have the option of doing a custom space to sales. To change current setting:

- Press (2) at *Space to Sales* prompt
- Press (2) to change current setting
- Press (1) to scroll through available settings
- Press (2) to save setting
- Press (3) to exit mode



To customize your space to sales:

- Press (2) at *Space to Sales* prompt
- Press (1) until the display reads *Space to Sales – Custom*
- Press (2) and the display will begin to scroll the current configuration
- To change a selection assignment, press (2)
- To assign (flashing) or unassign (no flashing/steady) columns, press (2)
- Pressing (3) will ask *Save?*
- Press (2) to save and (3) to exit the mode

### ***Closed Door Password***

Allows you to set a password to access sales data only when the door is closed. Please note that this function will not work if the password is set at 0000.

- Press (2) at *Closed Door Password* mode.
- The current password will be displayed.
- To change current password, press (1) while each digit is flashing
- Press (2) to save and advance to next digit.
- Press (2) after the 4<sup>th</sup> digit to exit mode

### ***Set Language***

Allows you to program different languages on the controller. The current languages available are English, Spanish and French.

- Press (2) at *Set Language* mode.
- The current language will be displayed.
- To change current language, press (2) to start the language flashing.
- Press (1) to choose a language.
- Press (2) to save the language change.
- Press (3) to exit mode.

### ***Set Clock***

If the *Timing Features* in the *Configuration* mode are turned ON, you will have access to this mode. This mode allows you to set the current month, day, year, hour and minute.

To set the clock:

- Press (2) at the *Set Clock* prompt. You will be able to scroll through the following options by pressing (1)
  - *Enable ON/OFF* - This will turn the clock timer on or off.
  - *MM/DD/YYYY HH:MM* - This is the current time & date.
  - *Daylight Savings*
- To change current setting, press (2)
- The current setting will begin to flash.
- Press (1) to change current setting
- Press (2) to save current setting.



## **Lighting**

If the *Timing Features* in the *Configuration* mode are turned ON, you will have access to this mode. This mode allows you to turn the lights on/off with the internal timer.

- Press (2) when the display reads *Start Time 1* or *Start Time 2*
- Press (2) at *Start Time 1* or *Start Time 2*
- Press (2) at *Start Day 1* or *Start Day 2*
- Scroll through the days of the week or 'all' with (1)
- To change current setting, press (2)
- Change setting with (1)
- Save changes with (2)
- Press (1) at *Start 1 00.00* or *Start 2 00.00*
- Press (2) to change time
- Press (1) to set time
- Press (2) to save
- Press (3) to exit mode
- Repeat process with *Stop Time 1* or *Stop Time 2*

## **Refrigeration**

If the *Timing Features* in the *Configuration* mode are turned OFF, you will only have access to the following modes:

*Set Point Temperature*  
*Sensor Reading*  
*Degree Setting*  
*Fan Energy Mode*  
*Periodic Defrost Mode*

To change the set point temperature:

- Press (2) when the display reads *Refrigeration*
- The display will read *Set Point XX* with the current setting displayed.
- To change the setting press (2) and the current set point temperature will begin to flash
- Press (1) to increase the set point
- Releasing (1) and pressing again will decrease the set point
- Press (2) to save your change
- Press (3) to exit and return to the display to *Refrigeration*

To display the temperature:

- Press (2) when the display reads *Refrigeration*
- Press (1) until the display reads *Sensor Reading*
- Press (2) and the current temperature will be shown in Fahrenheit or in Celsius
- Press (3) to exit and return the display to *Refrigeration*





To change the degree scale:

- Press (2) when the display reads *Refrigeration*
- Press (1) until the display reads *Degree Setting*
- The display will show the current degree scale (Celsius or Fahrenheit)
- Press (2) and the degree scale will begin to flash
- Press (1) to choose your setting
- Press (2) to save your setting
- Press (3) to exit and return the display to *Refrigeration*

To change the Fan Energy Savings mode:

- Press (2) when the display reads *Refrigeration*
- Press (1) until the display reads *Fan*
- The display will read *Fan X* with the current setting displayed.
- To change the setting press (2) and the current Fan mode will begin to flash.
- Press (1) to increase the Fan mode
- Releasing (1) and pressing again will decrease the Fan mode
- Press (2) to save your change
- Press (3) to exit and return to the display to *Refrigeration*

To change the Periodic Defrost Mode:

- Press (2) when the display reads *Refrigeration*
- Press (1) until the display reads *Periodic Defrost*
- The display will show it on or off
- Press (2) and the setting value will flash
- Press (1) to choose your setting
- Press (2) to save your setting
- Press (3) to exit and return the display to *Refrigeration*

If the *Timing Features* in the *Configuration* mode are turned ON, you will have additional access to the following modes:

*Enable*

*Start Time 1 or Start Time 2*

*Start Day 1 or Start Day 2*

*Start 1 00:00 or Start 2 00:00*

*Stop Time 1 or Stop Time 2*

*Stop Day 1 or Stop Day 2*

*Stop 1 00:00 or Stop 2 00:00*



## **Sales Block 1 and 2**

Allows you to program the machine to turn off and on at regular intervals.

To program the blocking feature, you must enter the following information:

*Start Time* – When the machine turns off

*Start Days*

*Stop Time* – When the machine turns back on

*Stop Days*

*Selections*

## **Discount**

Allows you to program the machine to discount beverages at regular intervals.

To program the *Discount* feature, you must enter the following information:

*Start Time* – When the discounting begins

*Start Day*

*Stop Time* – When the discounting ends

*Stop Day*

*Selections*

*Amount* - Refers to the amount subtracted from the original vend price

## **Override**

Allows various items to be enabled or disabled depending on the status of an attached override switch.

Each of the following items can be enabled by setting an *ON* or disabled by setting an *OFF*.

*"Override Free Vend"*

*"Override Sales Blocking"*

*"Override Discount"*

*"Override Light Timing"*

*"Override Refrigeration"*

## **Return**

Exits the programming mode and returns the machine to stand-by.

## 12.3 WIRING DIAGRAM

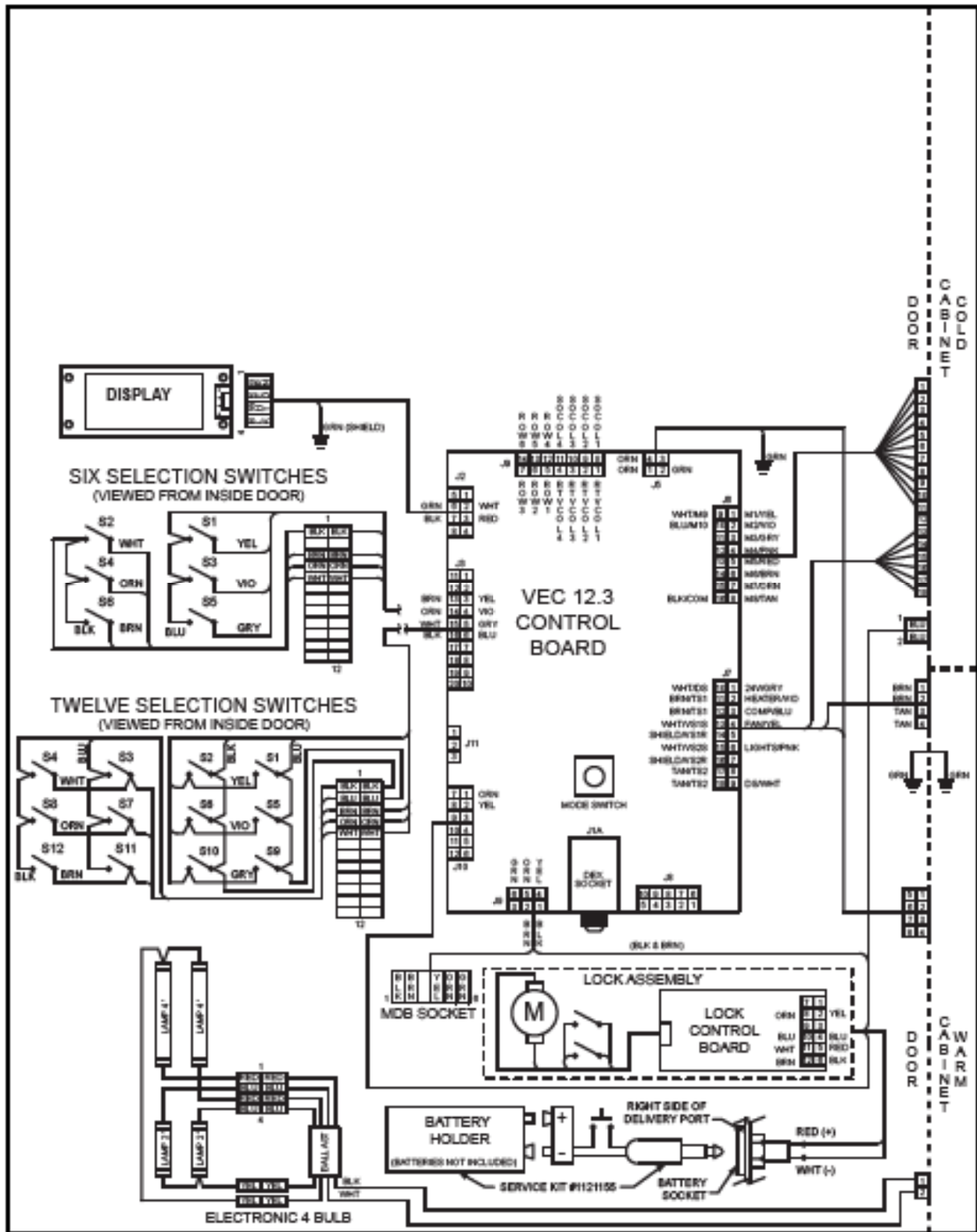

## 12.3 WIRING DIAGRAM

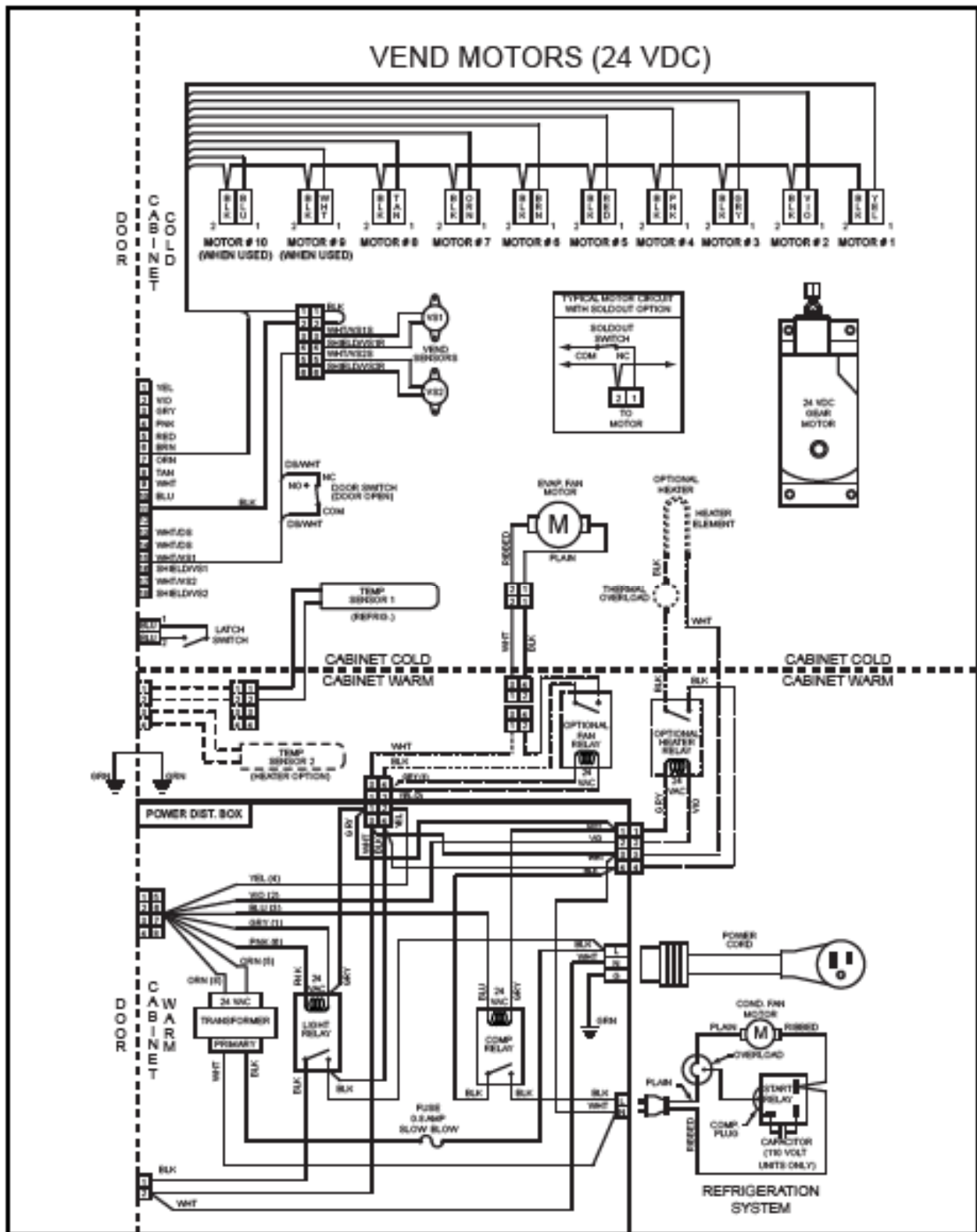



NOTES



**CABINET PARTS  
SECTION**



## READING A PARTS LIST

- I **ITEM NUMBER** is found in two locations:
    - A. It is on the drawing plate, and identifies the part and its location;
    - B. The same number is in the parts lists and ties the two together.
  
  - II **PART NUMBER** is the part number that has been assigned to a specific part by SandenVendo America, Inc., for easier identification.
  
  - III **QUANTITY REQUIRED** relates to the amount required of a part, or will be indicated by "A/R" (as required) to attach it to another part.
  
  - IV **PART NAME AND DESCRIPTION** is the general description for the part, for easier identification when ordering a like part.
  
  - V **HARDWARE** is identified by a letter in a hexagon. Refer to hardware list section or description and part numbers. See pages C-4 and C-5.
- 

















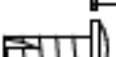







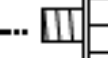



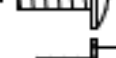



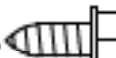

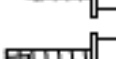

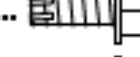

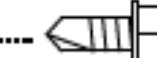

The example below will show how the parts are listed in the parts lists:

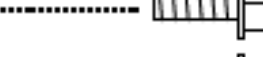
- 1. **VEND MOTOR ASSEMBLY:** This is the main assembly name, and any replaceable parts will be indented below the assembly.
  
- 2. **RETAINER CAM:** This is an individual part, and will be indented. These indented parts can be ordered separately, so you do not need to order the entire assembly.
  
- 3. Whenever an assembly is ordered, all the parts that are indented will be included in the assembly. Any hardware will be listed next to their corresponding parts.
  
- 4. Any parts that may be ordered separately will not have any indented parts listed below them.

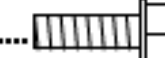



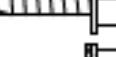





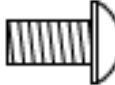

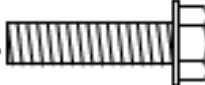

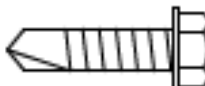



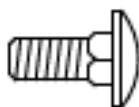

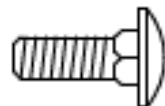









ITEM NO	DESCRIPTION	QTY REQ	PART NO.
1	VEND MOTOR ASSEMBLY	~	1115821
2	RETAINER CAM	1	1113244
3	TIMING CAM	1	1113238

















If an asterisk is listed below the parts list, it is an indication that special information is noted. There may be more than one asterisk (\*) (\*\*) (\*\*\*) denoting special notes.

## HARDWARE LIST

⬡	PART NO.	DESCRIPTION	PICTORIAL	
A	V802008	#6 X 1/4" MACHINE SCREW .....		
B	V802217	#6 X 7/8" TAPPING SCREW .....		
C	V800586	#6 X 3/8" TAPPING SCREW W/ LOCK WASHER .....		
D	V802214	#6 X 1/2" TAPPING SCREW (FOR PLASTIC) .....		
E	V802213	#6 X 5/16" TAPPING SCREW .....		
F	V800718	#10 X 3/8" TAPPING SCREW W/ LOCK WASHER .....		
G	V801421	#10 X 5/16" TAPPING SCREW .....		
H	V802212	#10 X 3/8" TAPPING SCREW .....		
I	V802047	#10 X 5/16" TAPPING SCREW W / LOCK WASHER .....		
J	V802141	#10 X 1/2" TAPPING SCREW .....		
K	V801422	#10 X 1/2" TAPPING SCREW .....		
L	V801489	#10 X 1/2" SELF DRILLING SCREW .....		
M	V802147	#10 X 1/2" TAPPING SCREW .....		
N	V802155	#10 X 5/8" TAPPING SCREW .....		
O	V802133	#10 X 3/4" SELF DRILLING SCREW .....		
P	V802152	#10 X 7/8" TAPPING SCREW W / LOCK WASHER .....		
Q	V800512	#10 X 1-3/8" TAPPING SCREW .....		
R	V802005-1	#10 X 1/2" CARRIAGE BOLT .....		
S	V801360	1/4" X 1/2" TAPPING SCREW W / LOCK WASHER .....		
T	V802198	1/4" X 1/2" TAPPING SCREW .....		

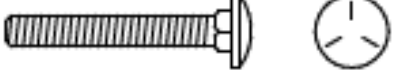

U	V800831	1/4" X 1/2" TAPPING SCREW .....		
V	V801343	1/4" X 1" TAPPING SCREW .....		
W	V801490	1/4" X 1" SELF DRILLING SCREW .....		
X	V802182	1/4" X 1 3/4" TAPPING SCREW .....		
Y	V802089	1/4" X 5/8" CARRIAGE BOLT.....		
Z	V801434	1/4" X 3/4" CARRIAGE BOLT .....		
AA	V801435	1/4" 20 X 1" CARRIAGE BOLT.....		
AB	V800287	1/4" X 3/8" BOLT.....		
AC	V800958	#8 NUT W / LOCK WASHER .....		
AD	V800952	#10 NUT W / LOCK WASHER .....		
AE	V800957	#10 NUT W/ LOCK WASHER .....		
AF	V802113	#10 LOCK NUT W / NYLON INSERT .....		
AG	V800959	1/4" NUT W / LOCK WASHER .....		
AH	387925	NYLON HEX NUT.....		
AI	V802178	1/4" NUT W/ SERRATED FLANGE.....		

<b>AJ</b>	<b>V801449</b>	<b>3/8" X 3/32 NUT.....</b>	
<b>AK</b>	<b>V801412</b>	<b>1/8" X .125 POP RIVET .....</b>	
<b>AL</b>	<b>V801471</b>	<b>1/8" X .419 POP RIVET .....</b>	
<b>AM</b>	<b>V801491</b>	<b>3/8" FLAT WASHER .....</b>	
<b>AN</b>	<b>V802043</b>	<b>PLASTIC SNAP PLUG .....</b>	
<b>AO</b>	<b>V801080</b>	<b>5/16" RETAINER RING .....</b>	
<b>AP</b>	<b>387450</b>	<b>COTTER PIN.....</b>	
<b>AQ</b>	<b>1032526</b>	<b>COTTER PIN.....</b>	
<b>AR</b>	<b>380315-1</b>	<b>SHOLDER SCREW .....</b>	
<b>AS</b>	<b>916923</b>	<b>CONDENSER NUT .....</b>	
<b>AT</b>	<b>337241-1</b>	<b>CUP WASHER .....</b>	
<b>AU</b>	<b>1121740</b>	<b>1/4" NYLON STANDOFF .....</b>	
<b>AV</b>	<b>V802220</b>	<b>1/4" X 3/4" TAPPING SCREW .....</b>	
<b>AW</b>	<b>1123719</b>	<b>SPACER.....</b>	
<b>AX</b>	<b>V802082</b>	<b>3/8" LOCK NUT W/ NYLOCK INSERT .....</b>	
<b>AY</b>	<b>V802111</b>	<b>#10 HEX NUT .....</b>	
<b>AZ</b>	<b>V802181</b>	<b>#10 X 1-1/4" CARRIAGE BOLT.....</b>	

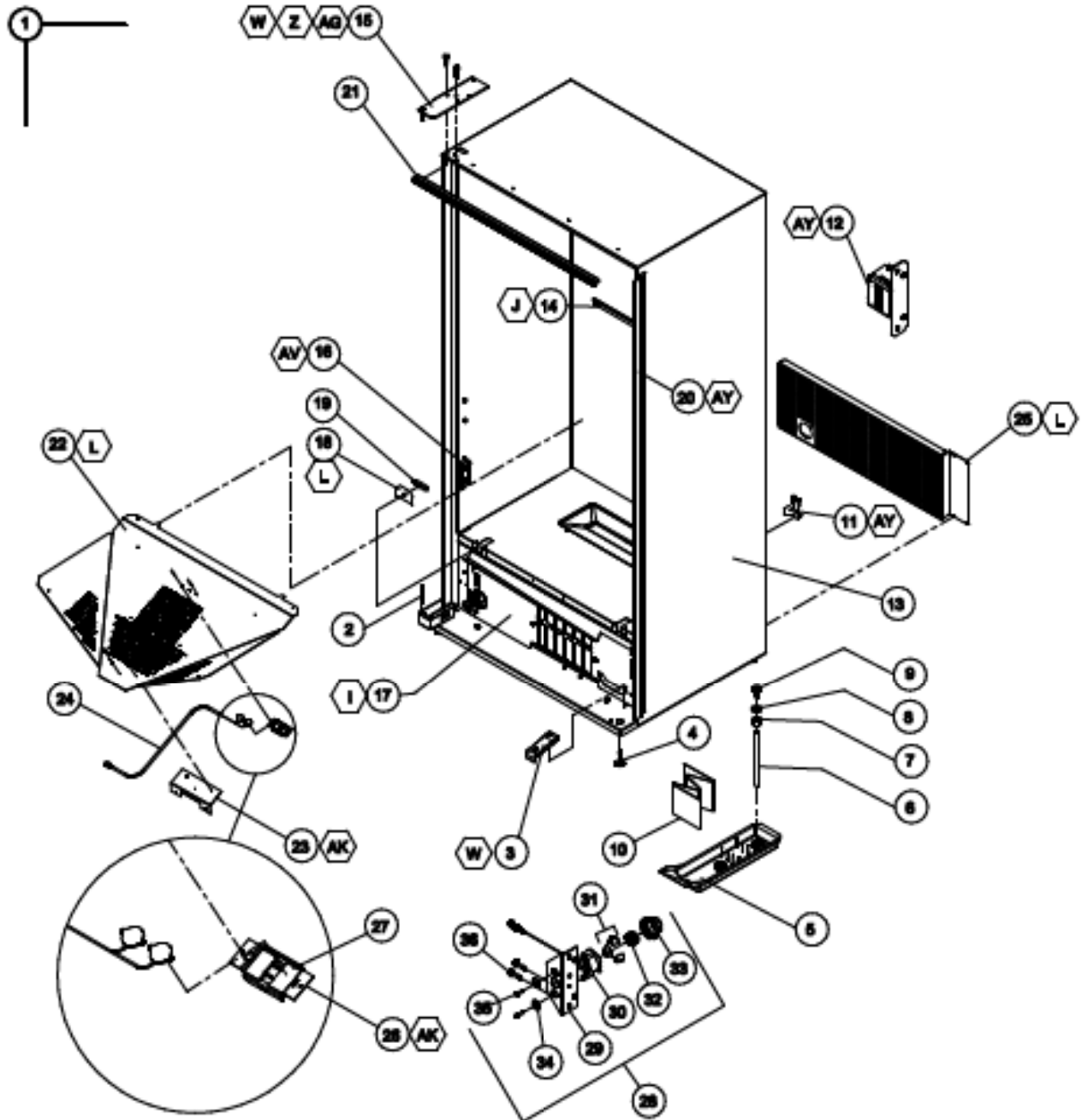



## CABINET ASSEMBLY

ITEM NO	DESCRIPTION	QTY REQ	PART NO.
1*	CABINET ASSEMBLY - FOAMED	1	~
2	HINGE PIN	1	389071
3	RAMP	1	1120387
4	LEVELING LEG	4	1050002
5	CONDENSATE PAN	1	1122475
6	DRAIN TUBE	1	1088449-1
7	NUT - DRAIN TUBE	1	387925
8	DRAIN TUBE GASKET	1	387837
9	DRAIN TUBE FUNNEL	1	1088678
10	FIBERGLASS EVAPORATION BOARD	1	1122728
11	BRACKET - REFRIGERATION	2	1123527
12	LATCH RECEPTACLE ASSEMBLY	1	1121186
13**	SIDE DECAL	2	**
14	STACK SUPPORT	1	1123018
15	TOP HINGE	1	2000805-03
16	BRACKET STACK SUPPORT	2	1079007
17	AIR DAM/KICK PANEL ASSEMBLY, 30"	1	1126880
	AIR DAM/KICK PANEL ASSEMBLY, 32"	1	1126880-1
18	DOOR SWITCH BRACKET	1	1126691
19	DOOR SWITCH	1	323007
20	OVERLAPPING DOOR GUARD - 72"	1	2001376
	OVERLAPPING DOOR GUARD - 79"	1	2002325
21	SEAL, 30"	1	1122500
	SEAL, 32"	1	1122500-1
22	VEND CHUTE, 30"	1	1123453
	VEND CHUTE, 32"	1	1123451
23	CHUTE BRACKET	1	1077864
24	DROP SENSOR	1	1122923
25	SAFETY SCREEN, 30"	1	1128567
	SAFETY SCREEN, 32"	1	1128775
26	DROP SENSOR MOUNTING BRACKET	1	1123601
27	FOAM PAD, DROP SENSOR	2	1123654
28***	QUICKER LOCK ASSEMBLY	1	1126566
29	LATCH BRACKET	1	1126428
30	NUT RETAINER	1	1123689
31	NUT SEGMENT	3	1033085
32	LOCK SPRING	1	389690
33	CAP	1	1111988
34	WASHER	1	389026
35	#8 X 1-1/4" PAN HEAD SCREW	2	V802139
36	1/4" X 1" HEX HEAD SCREW	4	V801490

FOR A COMPLETE LIST OF HARNESSSES, PLEASE SEE PAGE C-16

\*NOTE: WHEN ORDERING CABINET ASSEMBLY, PLEASE PROVIDE 9-CODE OR 11-CODE AND MANUFACTURER'S DATE CODE.

\*\*NOTE: WHEN ORDERING DECALS, PLEASE PROVIDE STYLE.

\*\*\*NOTE: QUICKER LOCK OPTION ONLY AVAILABLE IN 621 MODEL.

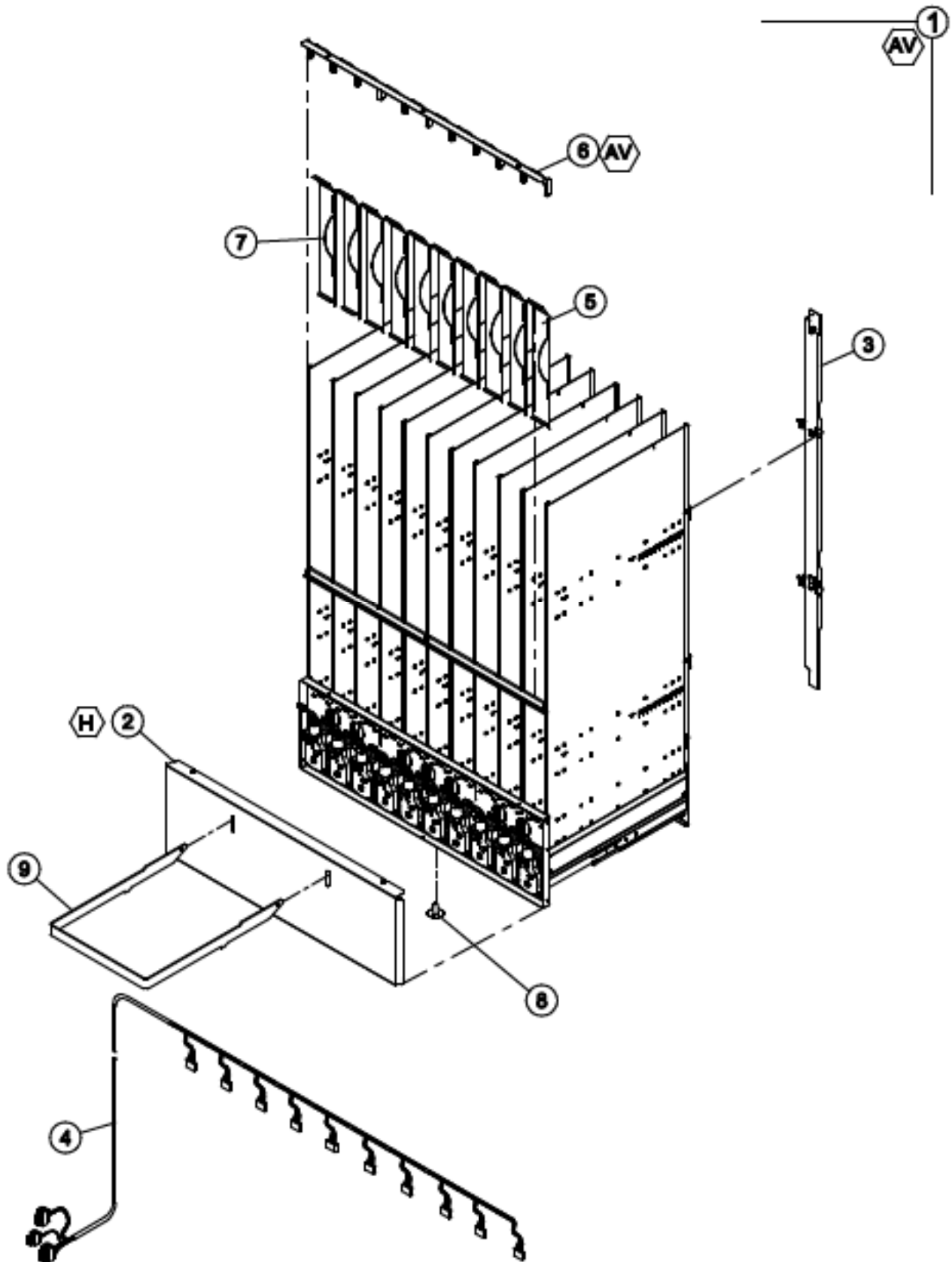



## STACK ASSEMBLY

ITEM NO	MODEL NUMBER		721	821	821
	DESCRIPTION	QTY REQ	PART NO.	PART NO.	PART NO.
1	STACK CHASSIS ASSEMBLY	1	1123591-02	1123591-03	1123591-01
2	MECH COVER	1	1125118	1125118	1123037
3	BACK SPACER ASSEMBLY	*	1123047-1	1123047	1123047-1
4	MOTOR HARNESS	1	1122918	1122918	1123050
~	MOTOR HARNESS W/ PRE-COOL	1	1124085	1124085	1124088
5	LOWER RETAINER	*	1124888	1124888	1124888
6	TOP STACK STRAP	1	1122809	1122809	1123039
7	FRICTION WIRE	*	1125607	1125607	1125607
8	SNAP IN PLUG	1	V802043	V802043	V802043
9	LOADING RACK	1	1123586	1123586	1123586

FOR A COMPLETE LIST OF HARNESES, PLEASE SEE PAGE C-16

\*MODELS 721 & 821 USE 10 EACH.

MODEL 821 USES 8 EACH.

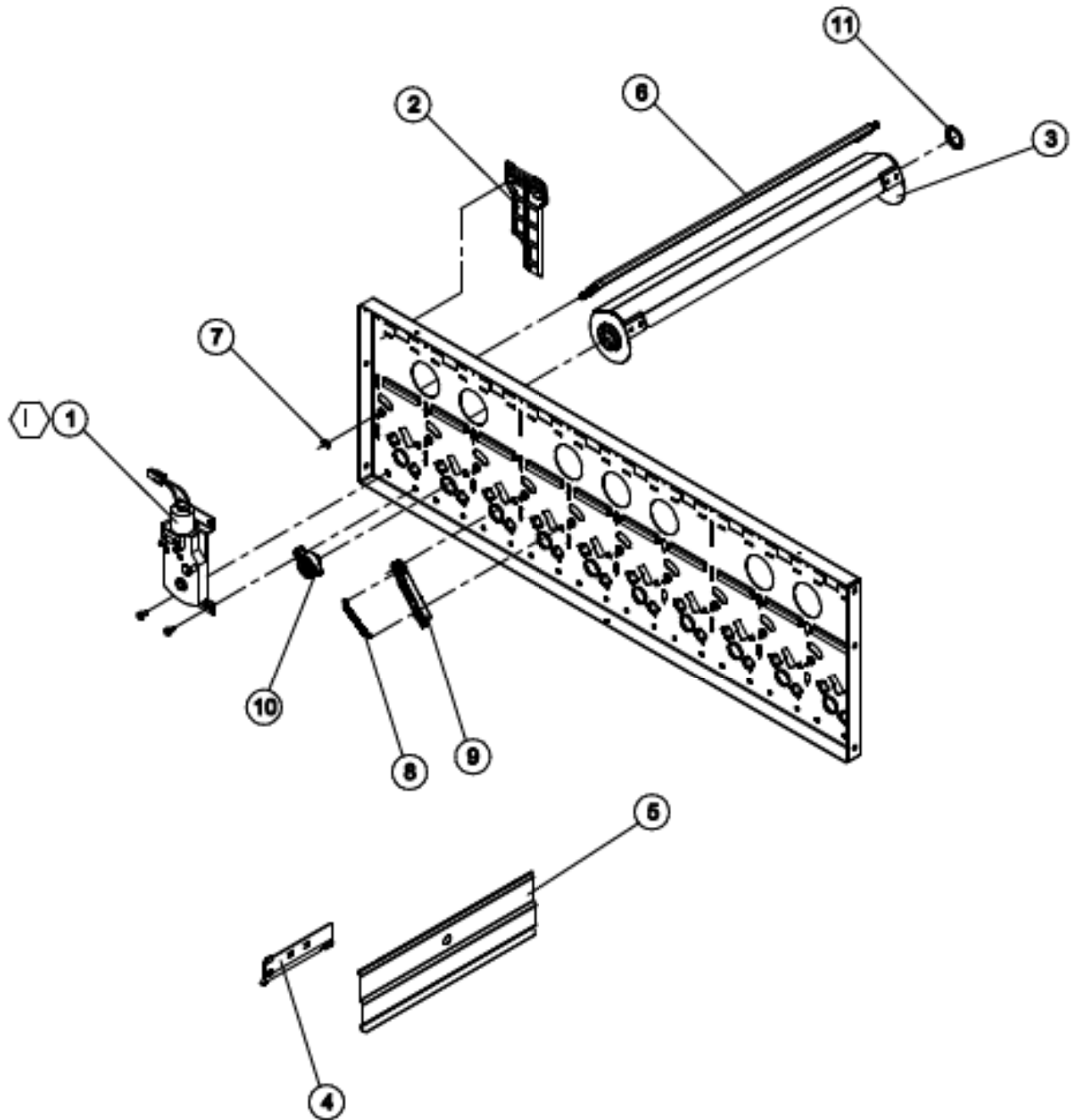



## MECH PLATE ASSEMBLY

ITEM NO	MODEL NUMBER	721/821		821	
	DESCRIPTION	QTY REQ	PART NO.	QTY REQ	PART NO.
1	VEND MOTOR ASSEMBLY	10	1122820	8	1122820
2	FRONT SPACER	10	1122814	8	1122814
3	VEND BUCKET	10	1122815	8	1122815
4	CAN CLIP	10	1122856	8	1122856
5	* PRODUCT SPACER, 2.4 DIA	AR	1122928	AR	1122928
6	GATE	10	1122818	8	1122818
7	E-CLIP - GATE	10	V801080	8	V801080
8	SPRING	10	390326	8	390326
9	GATE LINK	10	1122819	8	1122819
10	COUPLING CAM	10	1122817	8	1122817
11	REAR BUSHING	10	1122816	8	1122816

FOR A COMPLETE LIST OF HARNESES, PLEASE SEE PAGE C-16

\*DEPENDING ON PRODUCT



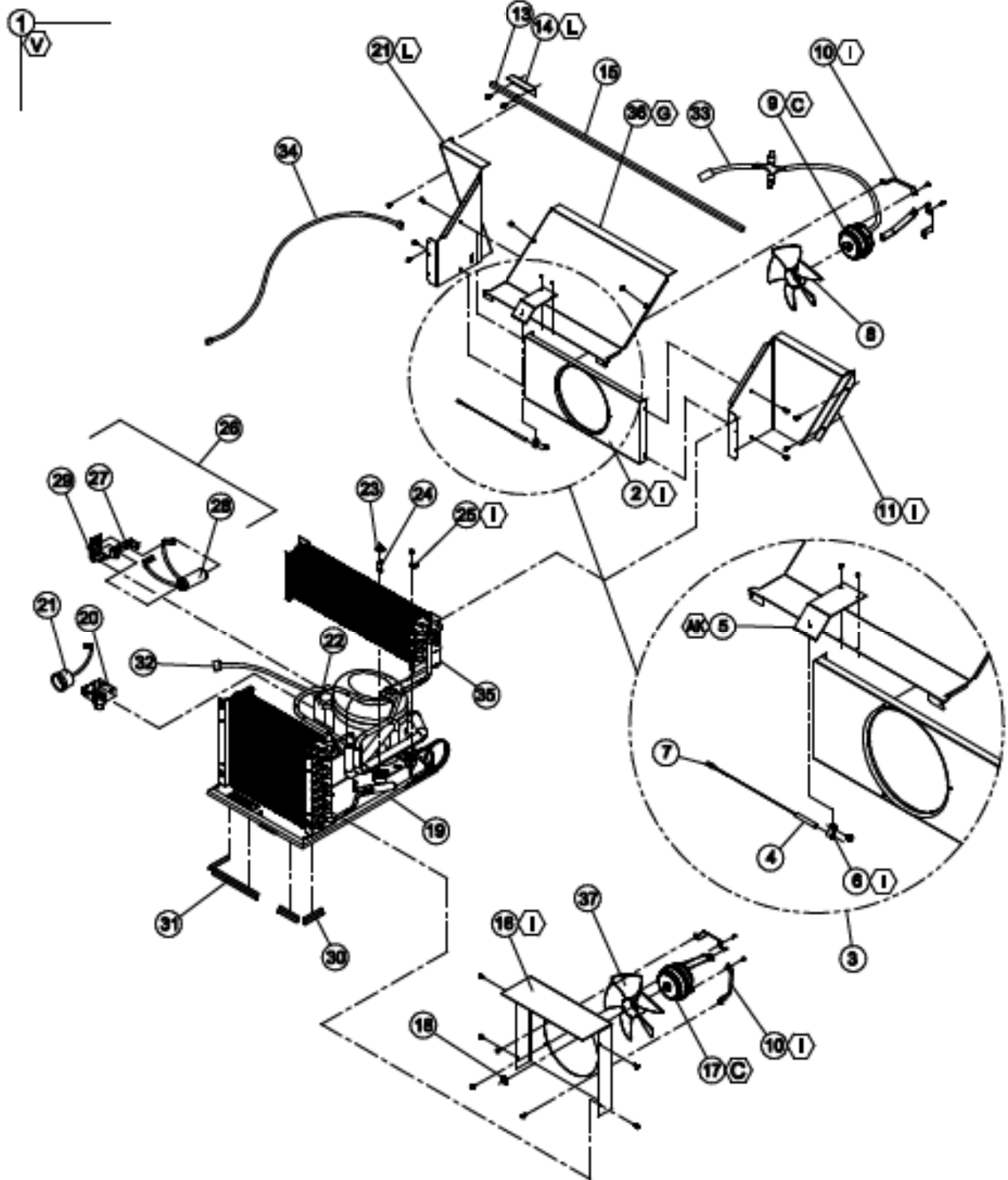



## REFRIGERATION ASSEMBLY

ITEM NO	DESCRIPTION	QTY REQ	PART NO.
1	REFRIGERATION ASSEMBLY D90 TE S 1/3 R134a CAP START	1	1123589
2	ORIFICE PLATE, SINGLE FAN	1	390228
3	TEMPERATURE SENSOR ASSEMBLY	1	1124254
4	TEMPERATURE SENSOR	1	1122924
5	TEMPERATURE SENSOR BRACKET	1	1124156
6	CLAMP, 1/4"	1	324099-2
7	PUSH MOUNT CLAMP	1	384692
8	EVAPORATOR FAN BLADE	1	1113562
9	FAN MOTOR - EVAPORATOR	1	42321-17
10	BRACKET - FAN MOTORS	6	1117996
11	RIGHT AIR BAFFLE - EVAPORATOR	1	1123564
12	SMALL AIR DUCT - EVAPORATOR	1	1124097
13	FOAM TAPE, 3.5"	1	1124421-2
14	EVAPORATOR EXTENSION BRACKET	1	1124158
15	FOAM TAPE, 32.5"	1	1124421
16	CONDENSER DUCT	1	1122413
17	FAN MOTOR - CONDENSER, 115V	1	1121770
18	FAN MOTOR CLIP - CONDENSER	1	V42323
19	BASE - REFRIGERATION	1	1122470
20	START RELAY (PART OF ASSY 513506066)	1	--
21	OVERLOAD PROTECTOR (PART OF ASSY 513506066)	1	--
22	COVER - OVERLOAD (PART OF ASSY 513506066)	1	--
23	CLIP - COMPRESSOR MOUNT	2	343874
24	STUD - COMPRESSOR MOUNT	2	390102
25	CLAMP, 5/16"	1	324099-3
26	CAPACITOR ASSEMBLY	1	1112805
27	BRACKET - CAPACITOR	1	1112848
28	CAPACITOR-START/END	1	1122999
29	CAPACITOR CLIP	1	1076481
30	EDGE TRIM - SHORT	3	388304-1
31	EDGE TRIM - LONG	1	388304-3
32	COMPRESSOR POWER HARNESS	1	1121019-1
33	EVAPORATOR FAN HARNESS	1	1122193
34	EVAPORATOR POWER HARNESS	1	1124185
35	EVAPORATOR	1	1122235
36	EVAPORATOR COVER	1	1124099
37	CONDENSER FAN BLADE	1	389614

FOR A COMPLETE LIST OF HARNESSES, PLEASE SEE PAGE C-16

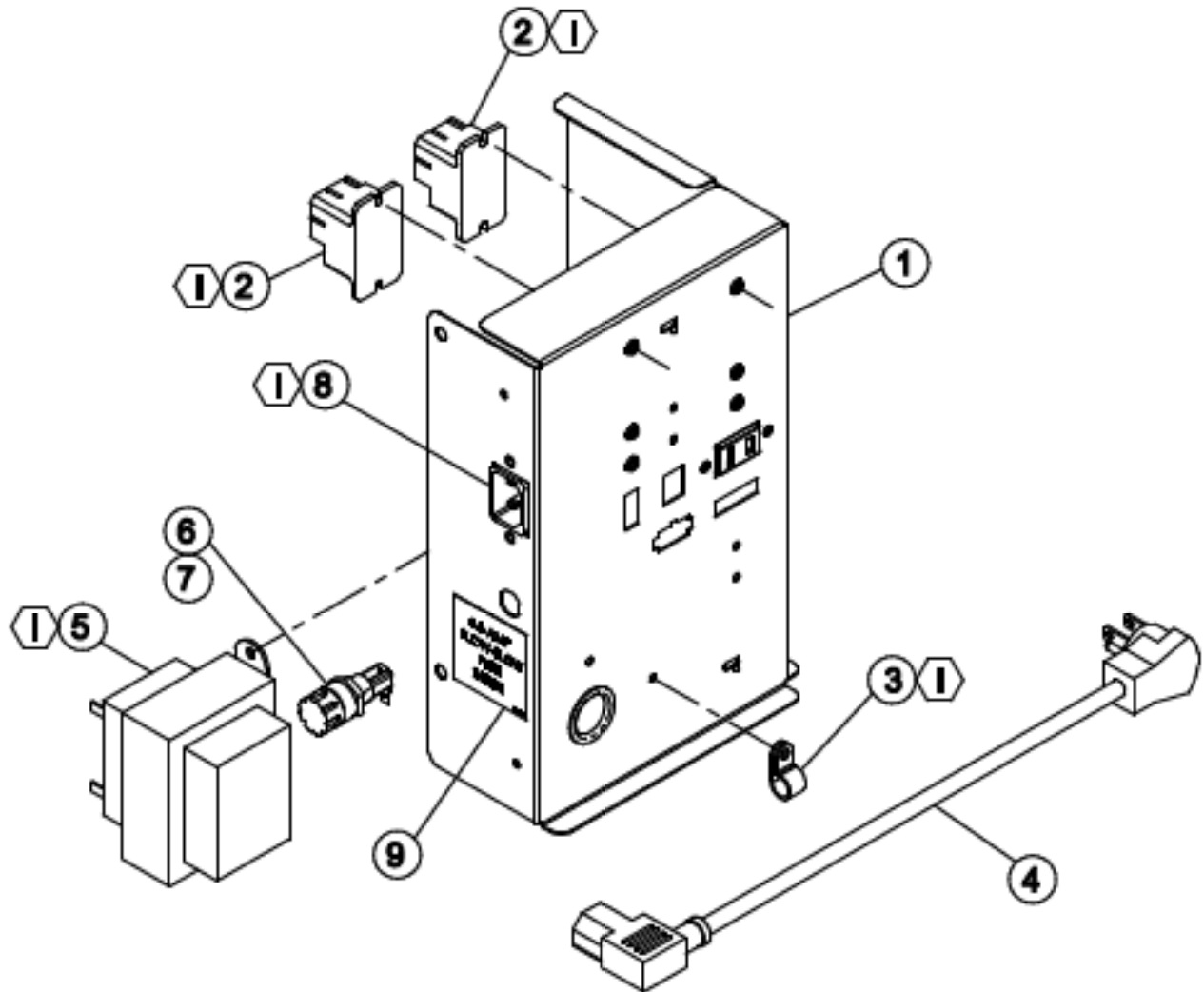



## POWER BOX ASSEMBLY

ITEM NO	DESCRIPTION	QTY REQ	PART NO.
1	POWER BOX HOUSING	1	1148515
2	RELAY	2	1128801
3	CLAMP	1	324099-3
4	CORDSET	1	1124281
5	TRANSFORMER	1	1111201
6	FUSEHOLDER	1	387986-50
7	0.8 AMP FUSE (NOT SHOWN)	1	1053884
8	POWER HARNESS	1	1123444
9	FUSE LABEL	1	1126640

FOR A COMPLETE LIST OF HARNESSES, PLEASE SEE PAGE C-16



## SANDENVENDO AMERICA HARNESS QUICK REFERENCE GUIDE HIGH VISIBILITY VENDORS

PART NO.	DESCRIPTION	PURPOSE	721	821	621
1122905	Door Harness	Connects motors, temp. sensors, transformer, drop sensors, and relays to the control board	X	X	X
1122918	Motor Harness - 10 select	Connects vend motors to the door harness	X	X	N/A
1123050	Motor Harness - 8 select	Connects vend motors to the door harness	N/A	N/A	X
1124085	Motor Harness w/ Pre-cool, 10 select	Connects vend motors to the door harness	X	X	N/A
1124086	Motor Harness w/ Pre-cool, 8 select	Connects vend motors to the door harness	N/A	N/A	X
1123075	Evaporator Fan Harness	Connects the evaporator fans to the power distribution box	X	X	X
1121087	Selection Harness - 6 sel, Right	Connects the selection buttons to the control board	X	X	N/A
1121085	Selection Harness - 6 sel, Left	Connects the selection buttons to the control board	X	X	N/A
1122777	Selection Harness - 3 sel, Right	Connects the selection buttons to the control board	N/A	N/A	X
1122778	Selection Harness - 3 sel, Left	Connects the selection buttons to the control board	N/A	N/A	X
1124876	Display Harness	Connects the display to the control board	X	X	X
1123679	Lock System Harness	Connects the electronic lock to the control board	X	X	X
1122609	Upper Lights Harness	Connects the upper lights to the lower lights	X	X	X
1122610	Lower Lights Harness	Connects the lower lights to the ballast	X	X	X



NOTES



**HVV DOOR  
PARTS SECTION**

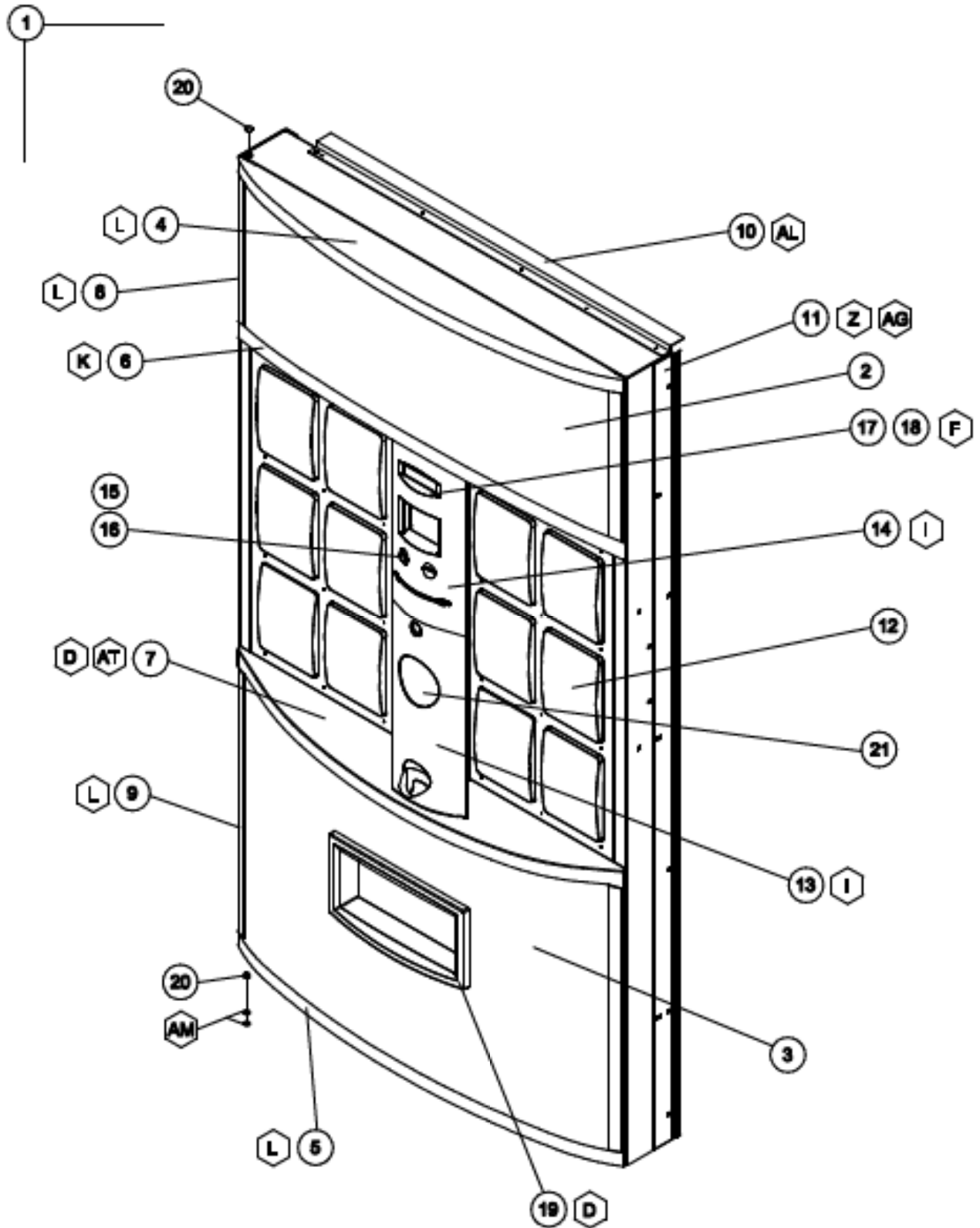





### V21 HVV DOOR FRONT

ITEM NO.	DESCRIPTION	QTY REQ	PART NO. 721	PART NO. 821	PART NO. 621
1	SERVICE DOOR, BLUE, W/O S/RTV SERVICE DOOR, BLUE, WITH S/RTV SERVICE DOOR, GREEN, W/O S/RTV SERVICE DOOR, GREEN, WITH S/RTV	1	1112818-35 1112818-38 1112818-39 1112818-40	1112818-37 1112818-38 1112818-41 1112818-42	1112818-60 1112818-61 N/A N/A
2	UPPER SIGN FACE **	1	**	**	**
3	LOWER SIGN FACE **	1	**	**	**
4	UPPER SIGN CAP, BLUE UPPER SIGN CAP, GREEN UPPER SIGN CAP, BLACK	1	1114341-2 1114341-4 1114341	1114341-2 1114341-4 1114341	1127305-1 1127305-2 1127305
5	LOWER SIGN CAP, BLUE LOWER SIGN CAP, GREEN LOWER SIGN CAP, BLACK	1	1114341-3 1114341-6 1114341-1	1114341-3 1114341-6 1114341-1	1127610-1 1127610-2 1127610
6	UPPER / MIDDLE SIGN CAP, BLUE UPPER / MIDDLE SIGN CAP, GREEN UPPER / MIDDLE SIGN CAP, BLACK	1	1121083 1121083-1 1121083-2	1121083 1121083-1 1121083-2	1122788 1122788-1 N/A
7	LOWER / MIDDLE SIGN CAP, BLUE LOWER / MIDDLE SIGN CAP, GREEN LOWER / MIDDLE SIGN CAP, BLACK	1	1121080 1121080-1 1121080-2	1121080 1121080-1 1121080-2	1122788 1122788-1 N/A
8	UPPER SIGN TRIM, 72", BLUE UPPER SIGN TRIM, 78", BLUE UPPER SIGN TRIM, 72", GREEN UPPER SIGN TRIM, 78", GREEN UPPER SIGN TRIM, 72", BLACK UPPER SIGN TRIM, 78", BLACK	2	1121100-1 - 1121100-4 - 1121100-7 -	- 1121100-2 - 1121100-6 - 1121100-8	1121100-1 - N/A N/A N/A N/A
9	LOWER SIGN TRIM, 72" & 78", BLUE LOWER SIGN TRIM, 72" & 78", GREEN LOWER SIGN TRIM, 72" & 78", BLACK	2	1121100 1121100-3 1121100-8	1121100 1121100-3 1121100-8	1121100 N/A -
10	RAIN GUARD (BLUE) RAIN GUARD (GREEN) RAIN GUARD (BLACK)	1	2006872 2006872-01 2000848	2006872 2006872-01 2000848	2006937 2006937-1 N/A
11	DOOR GUARD, 72", BLUE DOOR GUARD, 78", BLUE DOOR GUARD, 72", GREEN DOOR GUARD, 78", GREEN DOOR GUARD, 72", BLACK DOOR GUARD, 78", BLACK	1	1122178 - 1122178-2 - 2010131 -	- 1122178-1 - 1122178-3 - 2008603	1122178 - N/A N/A N/A N/A
12	SELECTION PANEL (SEE PAGE D-7)	-	-	-	-
13	LOWER CONSUMER PANEL, WITHOUT KEY	1	1121084-4	1121084-4	1121084-4
14	UPPER CONSUMER PANEL -WITHOUT DBV -WITHOUT DBV, CA FRENCH -LARGE DBV -UNIVERSAL LANGUAGE -UNIVERSAL LANG., WITHOUT DBV -UNIVERSAL LANG., WITHOUT DBV, LARGE COIN -UNIVERSAL LANG., LARGE DBV, LARGE COIN -UNIVERSAL LANG., LARGE DBV	1	1121084-11 1121084-8 1121084-8 1121084-11 1121084-7 1121084-8 1121084-9 1121084-10 1121084-11	1121084-11 1121084-8 1121084-8 1121084-11 1121084-7 1121084-8 1121084-9 1121084-10 1121084-11	1121084-11 1121084-8 1121084-8 1121084-11 1121084-7 1121084-8 1121084-8 1121084-10 1121084-11
15	SELECTION SPRING	1	1028868	1028868	1028868
16	COIN RETURN BUTTON	1	1060473	1060473	1060473
17	DISPLAY LENS	1	1121103	1121103	1121103
18	SERIAL DISPLAY, 2 X 20	1	1121184	1121184	1121184
19	EYELET TRIM	1	1121102	1121102	1121102
20	HINGE BUSHING	2	388084	388084	388084
21	PEPSI LOGO DECAL ** AGUAFINA LOGO DECAL ** MOUNTAIN DEW LOGO DECAL ** GATORADE LOGO DECAL **	1	**	**	**

\* NOTE: WHEN ORDERING OUTER DOOR ASSEMBLY, PLEASE PROVIDE 9-CODE OR 11-CODE AND MANUFACTURER'S DATE CODE.

\*\*NOTE: WHEN ORDERING SIGN FACE, PLEASE PROVIDE FRANCHISE AND STYLE.

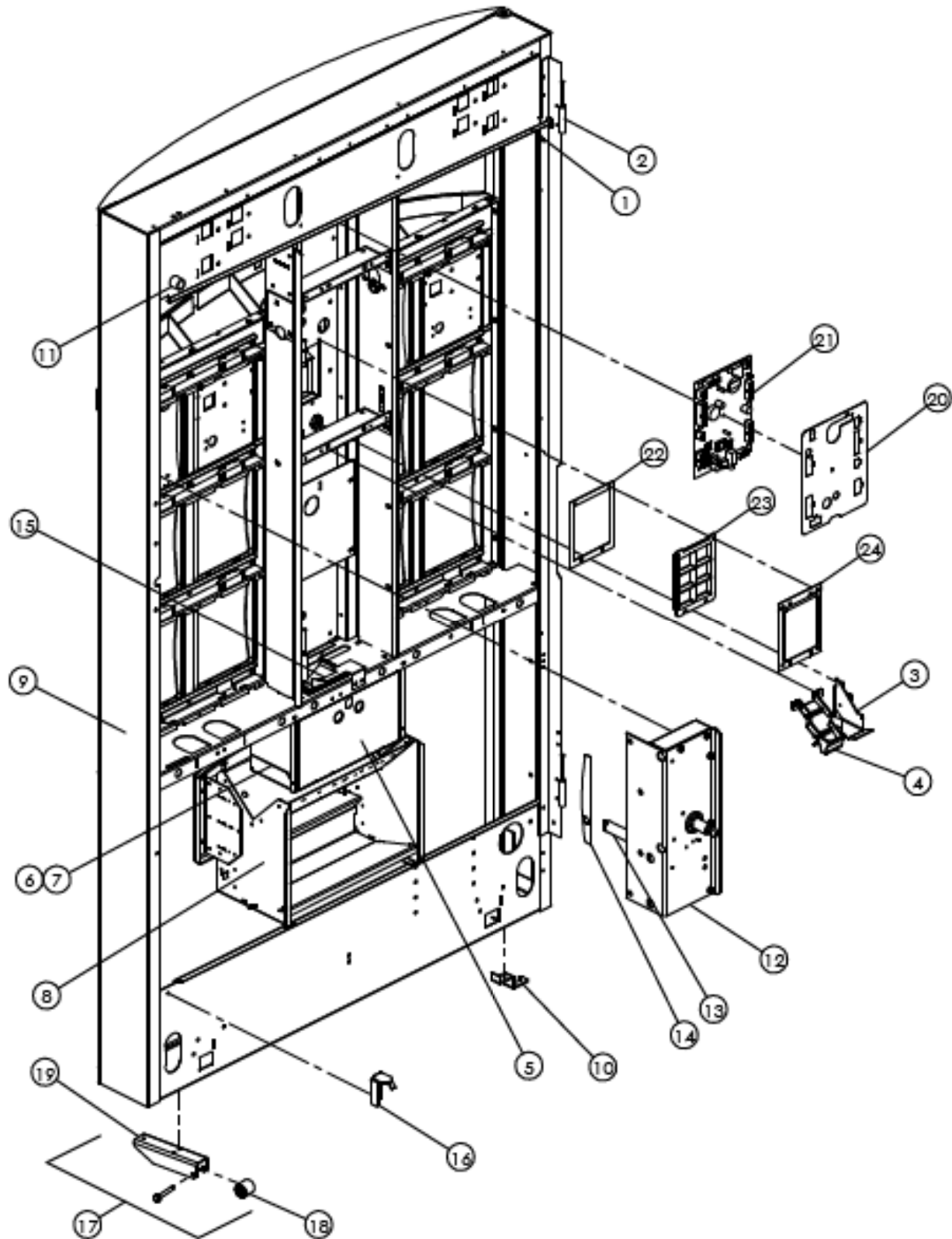



## V21 HVV DOOR BACK

ITEM NO	MODEL NUMBER		721	821	621
	DESCRIPTION	QTY REQ	PART NO.	PART NO.	PART NO.
1	RAIN GUTTER	1	1121204	1121204	1121204
2	INNER DOOR HINGE, MALE	1	1121287	1121287	1121287
3	COIN RETURN ASSEMBLY	1	2006236-43	2006236-43	2006236-43
	COIN RETURN PIVOT BRACKET		1121071	1121071	1121071
	COIN RETURN CRANK		1121072	1121072	1121072
	COIN INSERT SPRING		1060023	1060023	1060023
	SHOULDER WASHER		1122715	1122715	1122715
4	COIN INSERT CHUTE	1	1121066	1121066	1121066
5	COIN BOX ASSEMBLY	1	1121124-1	1121124-1	1121124-1
6	COIN RETURN CHUTE SHIELD	1	1122615	1122615	1122615
7	COIN BOX HOUSING	1	1124376	1124376	1124376
8	HOPPER ASSEMBLY	1	1124162	1124162	1124162
9	DOOR WELD, 72"	1	1121120-3	~	~
	DOOR WELD, 78"		~	1121120-4	1121120-4
10	LOWER HINGE HOOK	1	1121923	1121923	1121923
11	DOOR BUMPER (HEYCO 2551)	1	1036912	1036912	1036912
12	LOCK ASSEMBLY, HT2-TT *	1	1123073	1123073	1123073
13	TRITEQ LOCK LIGHT PIPE/SHROUD	1	1123640	1123640	1123640
14	LIGHT PIPE SHIELD	1	1123641	1123641	1123641
15	COIN RETURN CHUTE	1	1121065	1121065	1121065
16	INNER DOOR RAMP	1	1121714	1121714	1121714
17	DOOR ROLLER ASSEMBLY	1	1120564	1120564	1120564
18	DOOR ROLLER	1	1120388	1120388	1120388
19	DOOR ROLLER BRACKET	1	1120552	1120552	1120552
20	ELECTRONIC CONTROLLER COVER	1	1123529	1123529	1123529
21	VEC 12.3 PCBA	1	1123053-XX	1123053-XX	1123053-XX
22	DBV GASKET	1	1086759	1086759	1086759
23	DBV PLUG	1	388216-1	388216-1	388216-1
24	DBV INSERT (PLUG) BK	1	2000856	2000856	2000856
25	DOOR HARNESS (NOT PICTURED)	1	1122905	1122905	1122905

\* NOTE: T-HANDLE OPTION IS AVAILABLE FOR MODEL 621 ONLY. SEE PAGES PD-12 TO PD-13.

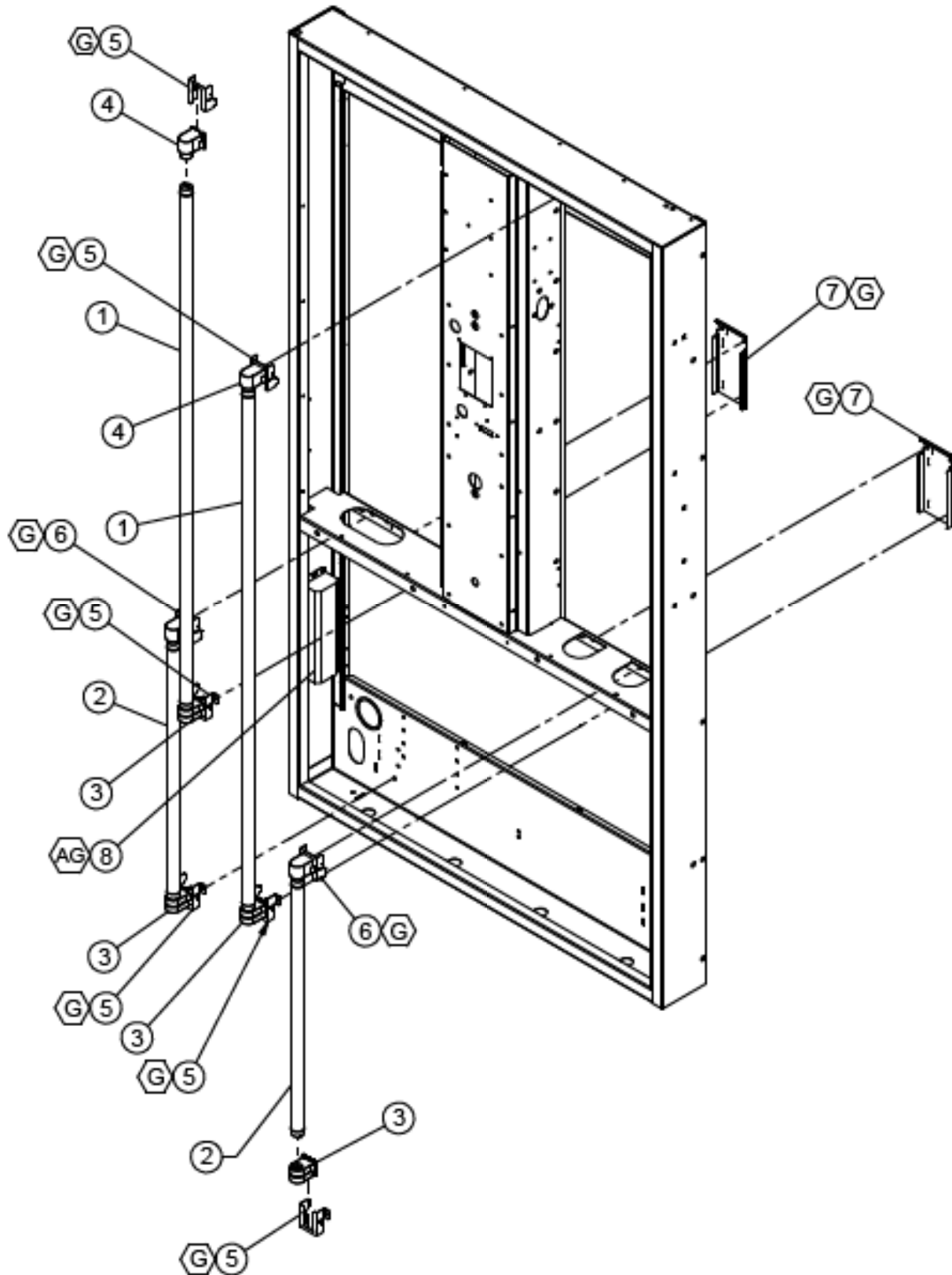



## V21 HVV U.S. LIGHTING

ITEM NO	DESCRIPTION	QTY REQ	PART NO.
1	LAMP, T-8, 4"	2	1121173-2
2	LAMP, T-8, 2"	2	1121173
3	LAMPHOLDER, FIXED	2	388531
4	LAMPHOLDER, PLUNGER	2	388532
5	LAMP BRACKET, 90°	8	1126231B
6	LAMP BRACKET, STRAIGHT	2	1126231-2B
7	VERTICAL SUPPORT, MIDDLE	2	1125176
8	BALLAST, 120V/60HZ	1	1127052
9	RAIN CURTAIN, BALLAST (NOT SHOWN)	1	1125150
10	RAIN CURTAIN, LIGHTS, T8 (NOT SHOWN)	1	1121838-1

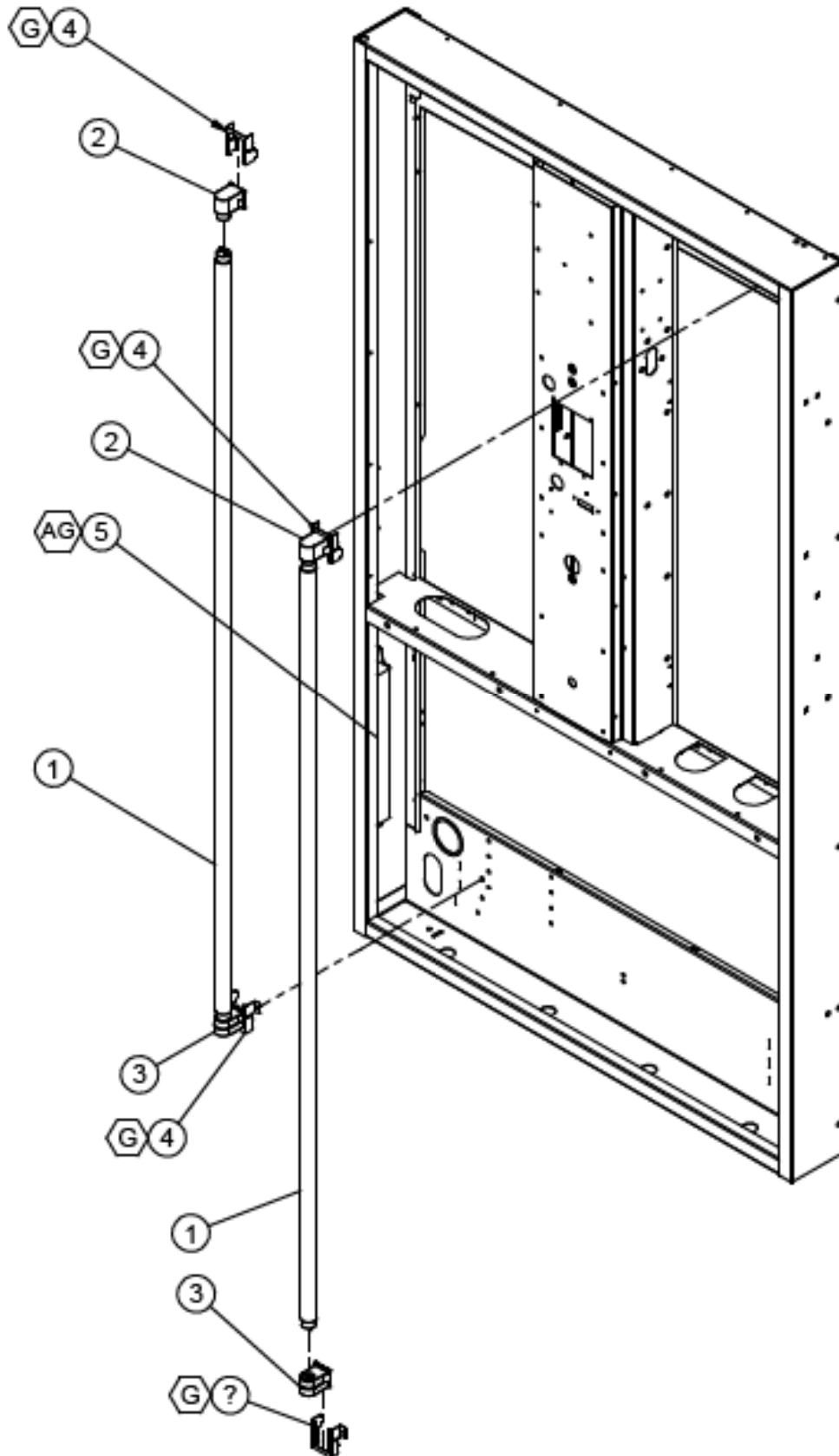



## V21 HVV INTERNATIONAL LIGHTING

ITEM NO	DESCRIPTION	QTY REQ	PART NO.
1	LAMP, T-8 (FOR MODEL 721) LAMP, T-8 (FOR MODEL 821)	2	1121030 1119340
2	LAMPHOLDER, PLUNGER	2	388532
3	LAMPHOLDER, FIXED	2	388531
4	LAMP BRACKET	4	1126231B
5	BALLAST, 220V (FOR MODEL 721) BALLAST, 220V/240V (FOR MODEL 821)	1	1120450 1124848
6	RAIN CURTAIN, BALLAST (NOT SHOWN)	1	1125150
7	RAIN CURTAIN, LIGHTS, T8 (NOT SHOWN)	1	1121838-1

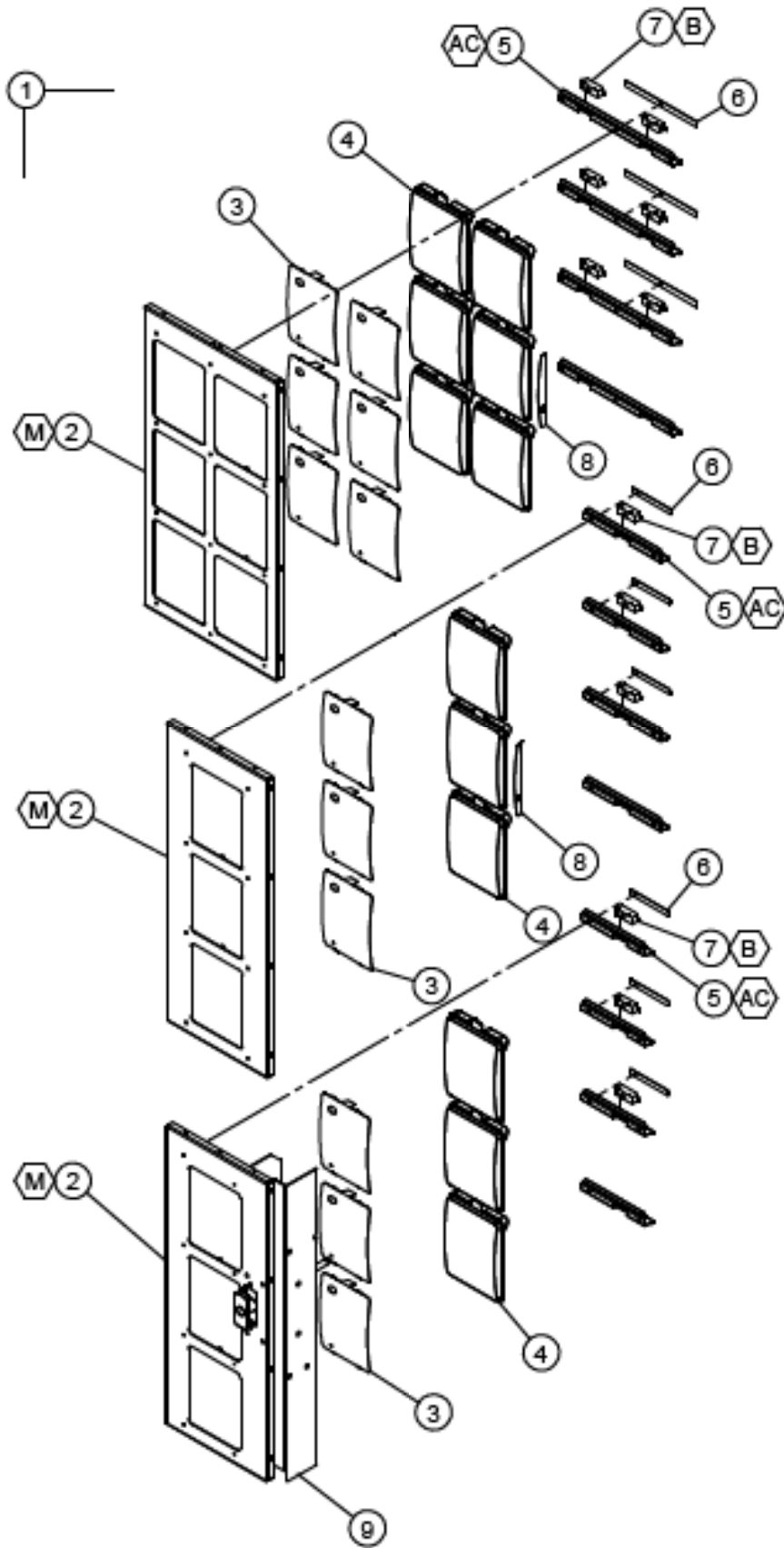

PD-10





## V21 HVV SELECTION PANEL ASSEMBLY

ITEM NO	MODEL NUMBER		721/821	621
	DESCRIPTION	QTY REQ	PART NO.	PART NO.
1	BUTTON ASSEMBLYS:			
	RIGHT PANEL ASSEMBLY, 6 SELECTION, BLUE	2	1122613	N/A
	LEFT PANEL ASSEMBLY, 6 SELECTION, BLUE	2	1122613-1	N/A
	SOLD OUT/READY TO VEND ASSY, RIGHT, 6 SEL, BLUE	2	1122613-2	N/A
	SOLD OUT/READY TO VEND ASSY, LEFT, 6 SEL, BLUE	2	1122613-3	N/A
	RIGHT PANEL ASSEMBLY, 6 SELECTION, GREEN	2	1122613-6	N/A
	LEFT PANEL ASSEMBLY, 6 SELECTION, GREEN	2	1122613-7	N/A
	SOLD OUT/READY TO VEND ASSY, RIGHT, 6 SEL, GREEN	2	1122613-8	N/A
	SOLD OUT/READY TO VEND ASSY, LEFT, 6 SEL, GREEN	2	1122613-9	N/A
	RIGHT PANEL ASSEMBLY, 6 SELECTION, BLACK	2	1122613-20	N/A
	LEFT PANEL ASSEMBLY, 6 SELECTION, BLACK	2	1122613-21	N/A
	SOLD OUT/READY TO VEND ASSY, RIGHT, 6 SEL, BLACK	2	1122613-22	N/A
	SOLD OUT/READY TO VEND ASSY, LEFT, 6 SEL, BLACK	2	1122613-23	N/A
	RIGHT PANEL ASSEMBLY, 3 SELECTION, BLUE	2	N/A	1122613-4
	LEFT PANEL ASSEMBLY, 3 SELECTION, BLUE	2	N/A	1122613-5
RIGHT PANEL ASSEMBLY, 3 SEL, T-HANDLE OPTION, BLUE	2	N/A	1122613-24	
2	BUTTON PANEL, BLUE	2	1121121	1122884
	BUTTON PANEL, T-HANDLE, BLUE (RIGHT SIDE ONLY)	1	N/A	1122884-2
	BUTTON PANEL, GREEN	2	1121121-01	1122884-1
	BUTTON PANEL, BLACK	2	1121121-03	N/A
3	FLAVOR LABEL	**	**	**
4	SELECTION BUTTON	A/R	1121057	1121057
5	BUTTON RETAINER SWITCH MOUNT, 6 SEL	8	1121070	N/A
	BUTTON RETAINER SWITCH MOUNT, 3 SEL	4	N/A	1122619
	BUTTON RETAINER SWITCH MOUNT, 3 SEL, T-HANDLE	4	N/A	1126109
6	FLAT SPRING	A/R	1121112	1122622
7	2-TERMINAL SWITCH	A/R	1120885	1120885
8	LIGHT PIPE SHIELD	1	1123641	1123641
9	T-HANDLE LOCK ASSEMBLY (SEE PAGES PD-12 TO PD-13)	~	~	~

\*\*NOTE: WHEN ORDERING FLAVOR LABELS, PLEASE PROVIDE FRANCHISE AND STYLE.

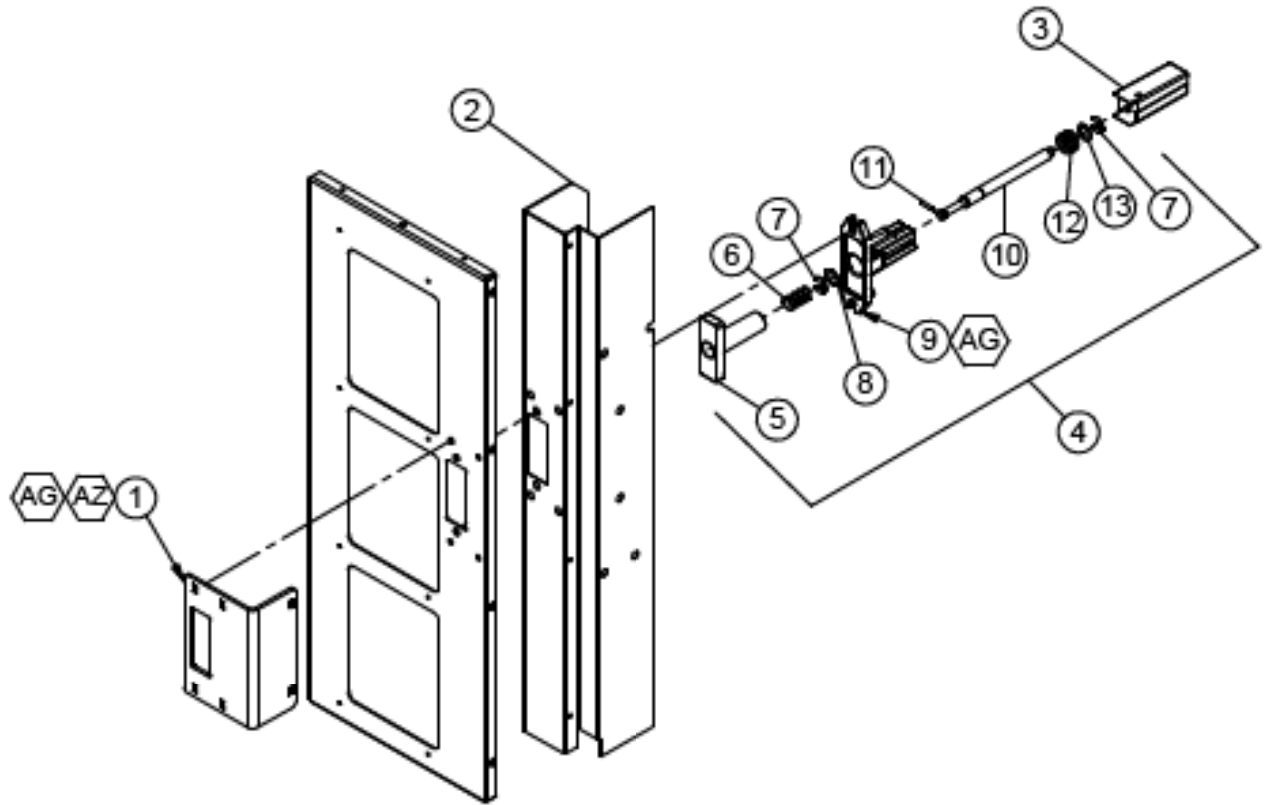



## V21 HVV T-HANDLE ASSEMBLY

ITEM NO	DESCRIPTION	QTY REQ	PART NO.
1	LOCK COVER PLATE, BLUE	1	1126568
2	LOCK SHIELD	1	1126218
3	LOCK STUD COVER	1	1121817-1
4	T-HANDLE LOCK ASSEMBLY	1	1126557
5	T-HANDLE	1	1002392
6	SPRING	1	389691
7	E-RING RETAINER	2	388589
8	HEX WASHER	1	387600
9	FLANGE	1	1002384
10	LOCK STUD	1	1122399
11	PIN, LOCK STUD	1	387601
12	SPRING QUICKER LOCK	1	389690
13	WASHER	1	387718

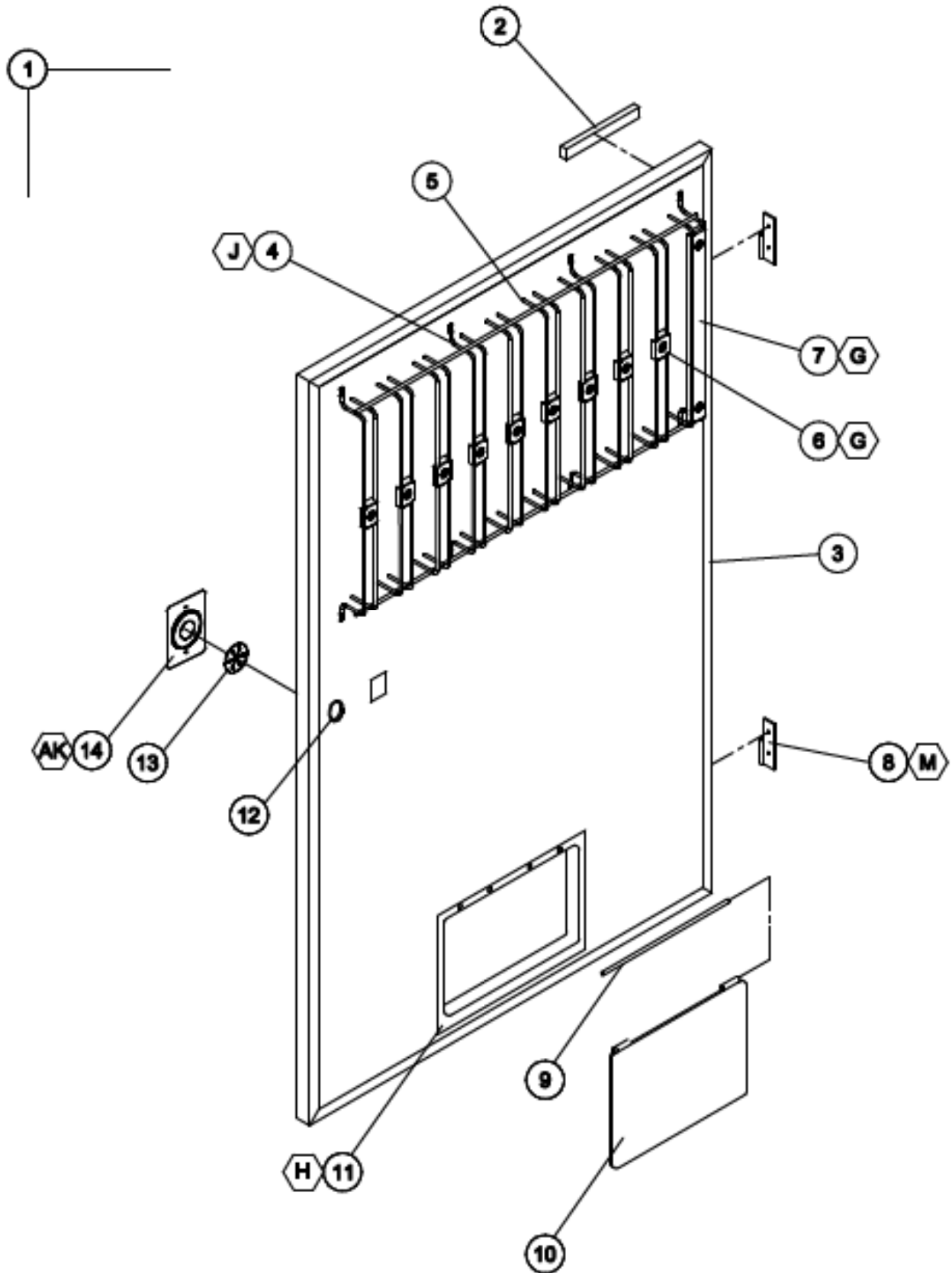



## V21 HVV INNER DOOR

ITEM NO	MODEL NUMBER		721	821
	DESCRIPTION	QTY REQ	PART NO.	PART NO.
1	INNER DOOR ASSEMBLY	1	134302-122	134302-127
2	RAIN SEAL, INNER DOOR, 7"	1	1111732-2	1111732-2
3	INNER DOOR SEAL	1	1075678	1075678-1
4	UPPER PRODUCT RETAINER ASSEMBLY	1	1125206-1	1125206-2
5	UPPER PRODUCT RETAINER	1	1124285	1124285-1
6	SHORT CLIP ASSEMBLY	9	1125261	1125261
7	LONG CLIP ASSEMBLY	1	1125262	1125263
8	INNER DOOR HINGE, FEMALE	2	1121286	1121286
9	HINGE PIN	1	389985	389985
10	REVERSABLE VEND FLAP	1	1013076	1013076
11	INNER DOOR EYELET	1	387273	387273
12	GROMMET	1	388090	388090
13	INNER DOOR LATCH	1	1121711	1121711
14	INNER DOOR LATCH BRACKET	1	1121712	1121712

## V21 HVV INNER DOOR LABELS - NOT SHOWN

DESCRIPTION	QTY REQ	PART NO.
WARNING/PATENTS, U.S. OR WARNING/PATENTS, INTL.	1	1125783-1 1125783
ERROR CODE LABEL, VEC 12.3	1	1123717
PROGRAMMING LABEL, VEC 12.3	1	1123345
WIRING DIAGRAM LABEL, VEC 12.3	1	1127541
PRODUCT SET UP, V21	1	1126121
SPACE TO SALES, VEC 12.3	1	1123311



NOTES



**MAINTENANCE  
SECTION**



## MAINTENANCE

The following section is a basic guide for general maintenance and servicing of the vendor. This section is divided into three parts: (I) Preventative Maintenance, (II) Lubrication Guide, and (III) Care and Cleaning.

### I. PREVENTATIVE MAINTENANCE SUGGESTIONS:

Whenever a vendor is visited on its site, the following service should be performed. Preventative maintenance will help prevent future problems with the vendor.

- A. Observe the vendor and its surrounding area for any unusual indications of problems (rear of cabinet, obstructions of the air flow, dark spots on the sign face, etc.).
- B. Open the door and visually check the inside of the vendor (water accumulation, rust marks, moisture around the edges of the inner door, etc.).
- C. Check the fluorescent lamps, replace as necessary. Replace all lamps within 24 to 48 hours of burnout. This will prevent damage to the ballast.
- D. Check the product temperature for proper cooling.
- E. Check the evaporator drain for obstruction; water in the evaporator area must drain to the condensation pan.
- F. Empty condensation pan.
- G. Clean the condenser filter.
- H. Check that evaporator fan(s) run normally.
- I. Check that the compressor and condenser fan run normally.
- J. Investigate any unusual sounds (fan blades hitting something, refrigeration lines rattling, etc.).
- K. Clean coin acceptor.
- L. Check for proper operation of the coinage mechanism by inserting all denominations of coins accepted by the vendor.
- M. Test the vendor and make a report on the problems.
- N. For electronic lock maintenance, refer to Triteq Lock and Security Users Manual

### II. LUBRICATION GUIDE:

Lubricate indicated areas as directed on the chart below.

INTERVALS	PARTS	LUBRICANT
Every six months	Top door hinge, hinge pin at the base of cabinet.	Grade two, high low temperature grease
As necessary	Pivot area of bucket and gate	Grade two, high low temperature grease





### III. CARE AND CLEANING

**DO NOT USE WATER JET FOR CLEANING.**

**AVOID USING WATER OR ANY OTHER LIQUIDS NEAR ELECTRONIC COMPONENTS**

- A. GENERAL PROCEDURE (painted metal areas)  
Wash the vendor with soap and water. The exterior may be waxed with any good automobile wax.
- B. FRESH PAINT SPLASHES, GREASE, GLAZING COMPOUND REMOVAL  
Before drying, these elements may be removed by rubbing lightly with grade "A" Naptha (or equivalent grade solvent). After removal, use general cleaning procedure (listed above in A).
- C. LABELS AND STICKER REMOVAL  
Use any specialized label removal liquid. When the label material does not allow penetration of solvent (such as vinyl), the application of heat (ie – hot air gun) will soften the adhesive and promote removal. **CAUTION:** Excessive heat can cause surface damage. After the label is removed, use the general cleaning procedure (listed above in A).
- D. SCRATCH REMOVAL  
Remove or minimize hairline scratches and minor abrasions by using any good quality automobile polish. Test product before using.
- E. LEXAN SIGNS  
To clean Lexan sign faces the following procedure is recommended.
1. Wash sign with mild soap or detergent and lukewarm water.
  2. Using a soft cloth or sponge, gently wash the sign. **DO NOT SCRUB!**
  3. Rinse well with clean lukewarm water.
  4. Dry thoroughly with a chamois or cellulose sponge (to prevent water spotting). **DO NOT USE SQUEEGEE!**
- NOTE:** Most organic solvents, petroleum, spirits, or alcohol are **NOT** compatible cleaning materials for Lexan signs. Usage of those materials could permanently damage the sign.
- F. REFRIGERATION AREA  
The condenser and evaporator must be kept clean for efficient operation. Be sure all vanes and tubing are clean and clear of obstruction; this allows free passage of air. Clean with a brush, a vacuum cleaner or compressed air. Keep cabinet drain open; clean as necessary.



## **REFRIGERATION OPERATION**

The refrigeration operation section is divided into three areas: Basic Refrigeration Principle, Detailed Vending Machine Refrigeration Cycle, and Parts Description.

### **BASIC REFRIGERATION PRINCIPLE**

What a refrigeration system really accomplishes is the transfer of heat. A refrigeration system removes the excess heat from a refrigerated area and then transfers it to a condenser where it is dissipated. As heat is removed, the refrigerated area cools.

In vending machines, large quantities of the heat must be transferred rapidly, economically and efficiently. This process must be able to withstand continuous repetition, without loss of refrigerant, over an extended period. The most common system used in the vending industry is the vapor compression (or simple compression) cycle system. It consists of four basic elements: An evaporator, a compressor, a condenser, and a pressure-reducing device (all part of a sealed system).

The compression system operates at two pressure levels: The low evaporating pressure and the high condensing pressure. The refrigerant acts as the transport medium, in which heat is moved from the evaporator to the condenser; at the condenser, the heat is dissipated into the surrounding air.

The liquid refrigerant changes from a liquid to a vapor and back to a liquid again. This change of state allows the refrigerant to absorb, and rapidly discharge, large quantities of heat efficiently.

#### **BASIC VAPOR COMPRESSION SYSTEM CYCLE:**

In the evaporator, the liquid refrigerant vaporizes. This change occurs at a temperature low enough to absorb heat from the refrigerated space. The temperature of vaporization is controlled by the pressure maintained in the evaporator (the higher the pressure, the higher the vaporization point).

The compressor pumps the vapor from the evaporator, through the suction line, and to the condenser. The compressor takes the low pressure vapor and compresses it, increasing both the pressure and the temperature. The compressor pumps the vapor at a rate rapid enough to maintain the ideal pressure. The hot, high pressure vapor is forced out of the compressor, into the discharge line and then into the condenser.

Air is blown through the condenser, allowing heat to transfer from the condenser and into the passing air. As the heat is removed, the stored refrigerant is condensed into a liquid. The liquid refrigerant is stored in the lower tube of the condenser. This is where it flows through the capillary tube back into the evaporator, where the refrigeration cycle is repeated.



## DETAILED REFRIGERATION CYCLE

The following is a detailed refrigeration cycle as it applies to the refrigeration system installed in SandenVendo America equipment. (Refer to the flow chart in Figure 1.)

As the air temperature in the cabinet rises, the electronic temperature sensor reports the air temperature to the electronic controller. The electronic controller actuates the refrigeration control relay, which turns on both the compressor and condenser fan motor.

The evaporator fan pulls air from the front of the refrigerated space of the cabinet. It pulls the air through the evaporator, and blows it up the rear of the vend stack. (The evaporator fan runs continuously.) As the air passes through the evaporator, heat is drawn from the air and transferred to the liquid refrigerant. As the cooled air circulates through the vend stack, heat is drawn from the product and transferred to the circulating air. The heated air is again drawn through the evaporator where the heat is removed.

In the evaporator, the liquid refrigerant draws heat from the circulating air. As refrigerant receives heat, it vaporizes.

The compressor pumps the vapor from the evaporator and compresses it, increasing both pressure and temperature. The compressor forces the compressed vapor out, through the discharge line and into the condenser.

The condenser fan pulls air through the condenser. As the hot refrigerant vapor passes through the condenser tubes, heat is drawn from the vapor. This heat is dissipated into the passing air. The air then exits out the back of the vendor. As the refrigerant vapor in the condenser lines is cooled, it returns to a liquid state.

From the condenser the liquid flows to the drier. The drier removes any water and solid particles from the liquid refrigerant.

The cooled liquid refrigerant continues from the drier, through the capillary tube, to the evaporator. The capillary tube steadies the flow rate of the refrigerant. Its small inside diameter allows the pressure in the evaporator to remain low while the pressure in the condenser is high.

The cool refrigerant in the evaporator draws heat from the circulating air in the cabinet. As the temperature in the cabinet drops, the electronic temperature sensor reports the air temperature to the electronic controller. The electronic controller deactivates the refrigeration control relay, which turns off the compressor and condenser fan motor.

When the air temperature in the cabinet rises above the electronic controller's cut in setting, the compressor and the condenser fan engage again.

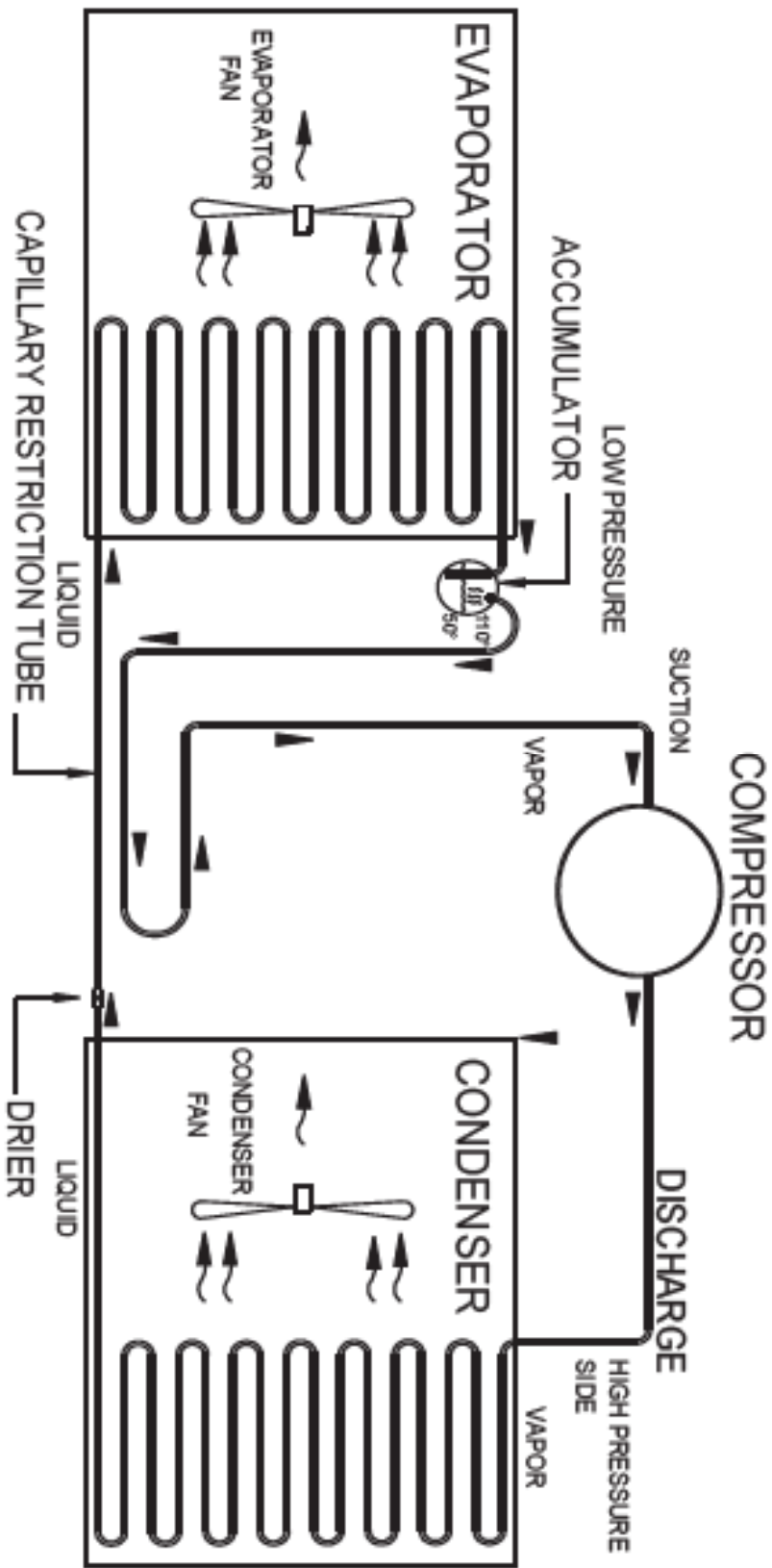

FIGURE 1



## **REFRIGERATION PARTS DESCRIPTION**

The compressor, condenser, drier, capillary tube, evaporator, and accumulator are part of a sealed system (refer to Figure 2). These items are not available separately.

### **COMPRESSOR**

The compressor takes in low pressure vapor and compresses it, increasing both the pressure and the temperature. The hot, high pressure gas is forced out to the condenser. The compressor and the motor that drives the compressor are sealed inside a housing. The compressor, as a unit, is mounted on the refrigeration base. The base is mounted in the bottom of the vendor, outside the sealed refrigeration space.

### **CONDENSER**

The condenser takes heat out of the high pressure vapor that it receives from the compressor. As the vapor passes through the condenser it cools and returns to a liquid state. The condenser is mounted to the refrigeration base near the front of the vendor. It is easily accessible for cleaning.

### **DRIER**

The drier is a molecular sieve strainer drier. It removes water and solid particles from refrigerant liquid. One side of the drier is connected to the outlet line of the condenser; the other side is connected to the capillary tube going to the evaporator.

### **CAPILLARY TUBE**

The capillary tube controls, at a steady rate, the flow of refrigerant liquid to the evaporator. It has a very small inside diameter to keep pressure in the evaporator low while the pressure in the condenser is high. It is the connecting link between the condenser and evaporator.

### **EVAPORATOR**

The evaporator is a heat transference device. It removes the heat from the air in a refrigerated space and transfers it to the refrigerant liquid. This liquid evaporates into a vapor and is removed by the compressor. The evaporator is mounted inside the refrigerated space of the cabinet, directly below the delivery chute.

### **ACCUMULATOR**

The accumulator traps any refrigerant liquid, which did not boil off into a vapor before reaching the compressor. The accumulator allows the refrigerant liquid to boil off as a vapor (preventing damage to the compressor). It also prevents suction line sweating. The accumulator is mounted in the suction line on the outline side of the evaporator.

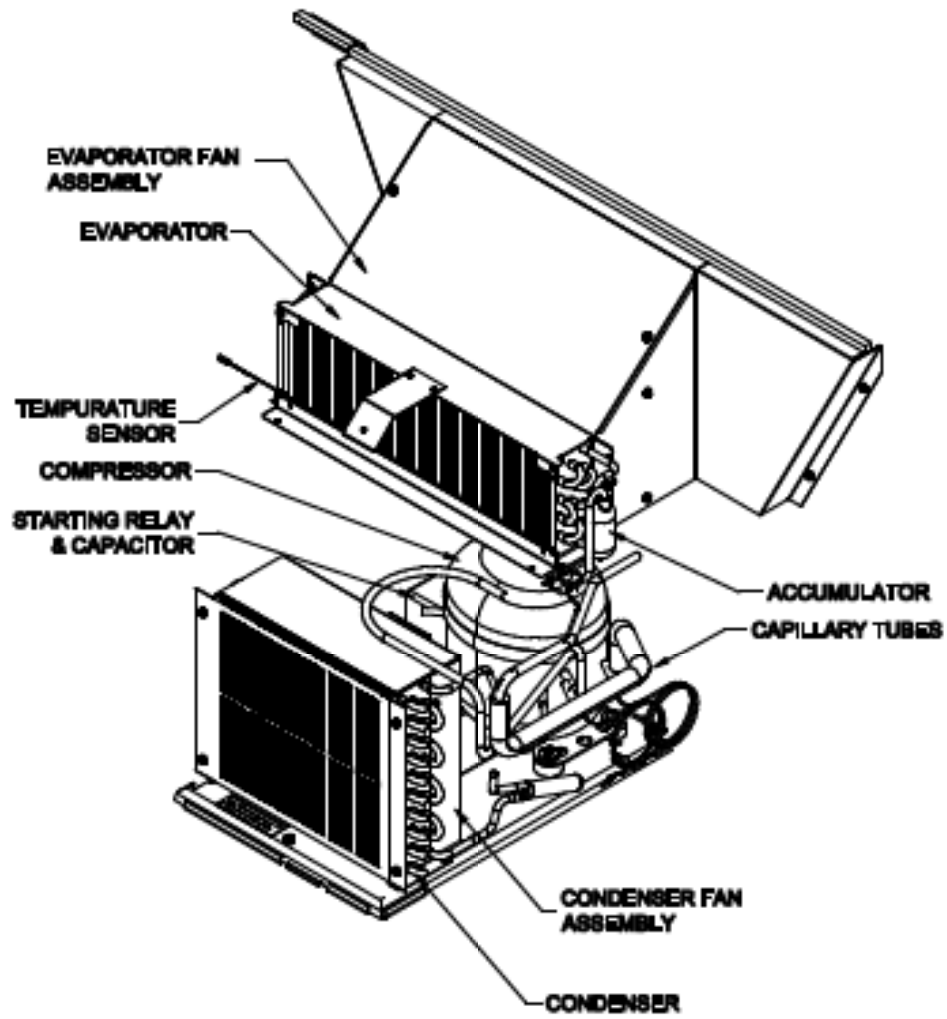

FIGURE 2



The parts listed below are not part of the sealed refrigeration system and are available separately.

**START CAPACITOR - P/N: 1124549**

The start capacitor is used to increase power during the start. This additional power will help get the compressor running in case there is any back pressure.

**STARTING RELAY – INCLUDED IN ASSEMBLY P/N 513506066**

The starting relay is mounted in the terminal box on the outside of the compressor under the housing. When the compressor first starts up, the starting relay closes and completes a starting circuit. When the compressor motor reaches operating speed, the starting relay opens and breaks the starting circuit.

**THERMAL OVERLOAD SWITCH – INCLUDED IN ASSEMBLY P/N 513506066**

The thermal overload switch is mounted in the terminal box on the outside of the compressor under the housing. If the compressor motor gets hot or draws too much current, the thermal overload opens and breaks the starting and running circuit of the motor. As the motor cools, the thermal overload closes, allowing the compressor to resist.

**TEMPERATURE SENSOR – P/N 1122924**

The thermistor is mounted in the inlet airflow of the evaporator. This monitors the air temperature and reports it to the electronic controller so that the controller can operate the refrigeration system via the power box.



NOTES





# **TROUBLESHOOTING SECTION**



## U.S. PARTS RETURN PROCEDURES

1. All parts returned must be accompanied by a material return tags (P/N 1122825) Tag must clearly state the reason for the return and the Return Goods Authorization Number received from your SandenVendo America, Inc. Customer Service Rep at 1-800-344-7216. (Return tags are available from our parts department upon request).
2. All parts should be properly wrapped and packed securely to avoid further damage.
3. To replace an inoperative part, please use the following instructions
4. Complete the return tag making sure to fill in ALL requested information to ensure prompt processing. Keep top (white) copy for your records. Attach tag to inoperative part and send it by the most inexpensive method of transportation (Federal Express Ground or Overnight Transportation) To: SandenVendo America, Inc. 4015 EAST RAINES ROAD, MEMPHIS, TENNESSEE 38118.
5. Be sure to check () the box marked "credit" and to fill in the invoice number covering the part sent to you or check the box marked "replace with like part".
6. If the box is marked for replace with like part, a like part will be shipped at no charge if our inspection shows that the inoperative part became defective during the warranty period.
7. If the box is marked for credit, a credit will be issued to cancel the invoice on which the replacement part was shipped. This credit will include any applicable prepaid transportation charges. To receive credit the inoperative part must be returned within 30 days from the date the replacement was shipped.
8. SandenVendo America, Inc. does not issue cash credit for the return of any part or accessory.

### REFRIGERATION UNIT RETURN PROCEDURE

1. All refrigeration units returned must be accompanied by a material return tag (P/N 1122826). Tag must clearly state the reason for the return and the Return Goods Authorization Number received from your SandenVendo America, Inc. Customer Service Rep at 1-800-344-7216. (Return tags are available from our parts department upon request).
2. All refrigeration units should be properly wrapped and packed securely to avoid further damage.
3. To replace an inoperative part, please use the following instructions.
4. Complete the return tag making sure to fill in ALL requested information to ensure prompt processing. Keep top (white) copy for your records. Attach tag to inoperative part and send it by the most inexpensive method of transportation (Federal Express Ground or Overnight Transportation) To: SandenVendo America, Inc. 10710 SANDEN DR. DALLAS, TX. 75238.
5. Be sure to check () the box marked "credit" and to fill in the invoice number covering the part sent to you or check the box marked "replace with like part".
6. If the box is marked for replace with like part, a like part will be shipped at no charge if our inspection shows that the inoperative part became defective during the warranty period.
7. If the box is marked for credit, a credit will be issued to cancel the invoice on which the replacement part was shipped. This credit will include any applicable prepaid transportation charges. To receive credit the inoperative part must be returned within 30 days from the date the replacement was shipped.
8. SandenVendo America, Inc. does not issue cash credit for the return of any refrigeration unit.

**\*Canadian and International customers please contact your Customer Service Representative for return instructions (see Safety section pages S13-S14).**



## Trouble Shooting Guide

The V21 vendor provides self-diagnostics to aid you in the trouble shooting process. Error codes are stored in the controller's memory when a system error is sensed. These codes can be accessed by following the procedure listed below.

The trouble shooting guide below contains information on how to solve problems with the 1) Vendo system; 2) Refrigeration system; 3) Peripherals; 4) Selection switches; and 5) Miscellaneous problems. The guide is divided into subsections with these headers.

### Accessing Error Codes Using Diagnostics Mode

Error	DESCRIPTION OF ERROR CODE	CHECKING METHOD	Corrective Action
<b>Vending Mechanism</b>			
Column Jam	Column jam - vend cycle for column "nn" did not start or complete.	Look in column to see if product is jammed against gate or bucket.	Clear jam, complete a test vend cycle. Complete an auto-homing cycle.
		Insure can clip is in correct position (reference set-up diagram).	Correct clip position, complete test vend and auto-homing cycle.
		Insure bottles are loaded correctly.	Load bottles correctly. See loading label.
Chute Sensor Error	Chute sensor error.	Tap chute and see if the LED on the control board turns green momentary.	Replace chute sensor assembly
<b>Selection Switches</b>			
Selection Switch Error #nn	Bad Selection Switch - Selection switch nn is actuated for more than 15 seconds while in the Customer Mode or Door Open Sales Test Mode.	Check the selection switch number shown in the detailed error code "nn" to see if: 1) the button is sticking; 2) the switch is sticking/defective; 3) the harness is wired wrong/shorted.	Try to correct the problem if one of the three items is found. If you can't correct it, then replace the component in question.
<b>Space to Sales</b>			
Unassigned Column. #nn	Column nn is not assigned to a selection	Access space-to-sales mode and go to custom space-to-sales.	Change space-to-sales setting as required. In some situations, it may be quicker to completely reset all space-to-sales.
		Check all selections for the column shown in the detailed error description (nn).	
Unassigned Sel. SW. #nn	Selection switch skipped - switch nn unassigned and a higher number switch is assigned.		Switch is assigned.



## Accessing Error Codes Using Diagnostics Mode (Continued)

Coin Changer			
Coin Communication	Changer communication error - no changer communication for more than 2 seconds.	1) Check that red light is flashing on control board.	If light is not flashing, there is no power to board. Check and replug any unplugged connections.
		2) Check to make sure service cord is plugged into the power distribution box.	If all connections are properly plugged in.
		3) Check fuse.	If fuse is blown replace it.
		4) Check transformer.	Replace transformer.
		2) Defective acceptor	Replace acceptor.
Tube Sensor	Tube sensor is defective -- reported by changer .	Check changer tubes for blockage	Clear tube blockage. If no blockage is found, replace changer.
Coin Inlet	Changer inlet chute blocked - no coins sensed for over 96 hours by the changer.	Check inlet chute for blockage. Drop coins in Sales Mode or Tube Fill Mode to test acceptance. Manually clear the error.	Clear inlet chute blockage. If no blockage found, replace changer. If acceptance rate is acceptable, system is OK. If acceptance rate is low or changer will not accept coins, replace changer.
Tube Jam	Tube pay out jam -- reported by changer.	Check changer tubes and payout for blockage.	Clear blockage, if found. If no blockage is found, replace changer.
Coin Read Only Memory	Changer check sum incorrect -- reported by changer.	Unplug machine, wait at least five seconds, replug machine. Manually clear the error.	If error does not clear, replace changer/acceptor.
			Replace acceptor.
Excessive Escrow	excessive escrow requests -- more than 255 requests since the last coin was sensed.	Check escrow lever and associated mechanisms. Close door then reopen. Check to see if error still occurs.	Manually clear the lever and error.
			Replace changer/acceptor.
Coin Jam	Coin jam - reported by changer.	Check changer/acceptor for jammed coins or other obstructions.	If no obstructions are apparent, replace changer/acceptor.
Low Acceptance	Low acceptance rate -- coin acceptance has fallen below 80%.	Check changer/acceptor for obstructions or dirt.	If no obstructions are apparent, and acceptance appears to be OK, this may be an indication of cheating attempts.
		Drop coins test acceptance.	If no obstructions are apparent and coins do not accept, or acceptance rate is poor, replace changer/acceptor.
Accept Disconnect	Disconnected acceptor -- indicates that an acceptor is unplugged.	Check coin mechanism plugs. Check for faulty harness wiring (see wiring diagram for circuit).	Correct connections.
Routing	Coin routing - indicates a coin was routed incorrectly.	Verify acceptor set-up using manufacturer's recommendations.	If acceptor was set up correctly, replace acceptor.



## Accessing Error Codes Using Diagnostics Mode (Continued)

<b>Dollar Bill Validator</b>			
Bill Validator Communication	Bill validator communications - No bill validator communication for 5 seconds.	If changer or card reader is being used, check for "Changer Communication" or "Rom Checksum" errors.	If there are no "Changer Communication" or "Rom Checksum" errors: 1) Check bill acceptor harness; 2) Replace bill acceptor. If there are those errors: 1) Check control board MDB harness.
		Unplug service cord. Wait at least five seconds. Plug in service cord. Manually clear the error.	
Bill Validator Full	Bill validator full - reported by validator (STACKER command).	Insure bill cashbox is empty and that the cashbox is properly closed and in place.	If cashbox appears to be OK, replace bill acceptor.
Bill Validator Motor	Bill validator motor is reported as defective by validator.	No test available.	Replace bill acceptor.
Bill Validator Jammed	Bill jammed -- reported by validator.	Check bill validator for obstructions or dirt.	If no obstructions are apparent, replace bill validator.
Bill Validator ROM	Bill validator check sum is incorrect.	Unplug service cord. Wait at least five seconds. Plug in service cord. Manually clear the error.	If error does not clear, replace bill acceptor.
Bill Validator Open	Bill validator is open.	Check that bill cashbox is closed and in correct position.	If cashbox appears to be OK, replace bill acceptor.
Bill Validator Sensor	Bill validator sensor is not functioning.	Check bill validator for obstructions or dirt.	If no obstructions are apparent, replace bill validator.
<b>Card Reader</b>			
Card Reader Communication	There is no card reader communication for 5 seconds.	If card reader/bill acceptor is being used, check for "Rom Checksum" error.	If there is no "Rom Checksum" error: 1) Check changer harness. 2) Replace card reader.
		Unplug service cord. Wait at least five seconds. Plug in service cord. Manually clear the error.	If there is a "Rom Checksum" error: Check control board MdB harness.
Card Reader	Most recent "non-transient error" from the card reader.	No test available.	Refer to card reader manual for corrective action.
<b>Refrigeration</b>			
Temp Sensor	The temperature sensor is defective or unplugged.	Check to see that temperature sensor harness is plugged into door harness at air dam area.	If the sensor is unplugged, replug it.
		Check for temperature sensor connection J7 on control board is plugged in.	
Not Cooling	System has failed to decrease temperature 1 per hour while the compressor is running.	Access relay mode (refer to programming manual).	Refer to refrigeration troubleshooting flow chart on the following pages.
		Check refrigeration settings (refer to refrigeration section of programming manual).	Change settings as required.



## Accessing Error Codes Using Diagnostics Mode (Continued)

Not Heating	Heater system has failed to increase temperature 1 per hour while heater is on.	Heater Circuit not properly wired.	Check electrical connections.
		Bad sensor on heater circuit.	Replace sensor.
		Defective heating element.	Replace heating element.
<b>Miscellaneous Problems</b>			
Door Switch	Door has been open for more than one hour.	Check the vendor's door switch to see if it's sticking or miswired.	Replace the door switch, if defective.
Ram Error	Ram check sum for service mode settings stored in non-volatile memory has been corrupted.	No test available	If error shows up frequently, replace the control board.
AC Low	AC voltage to the controller is less than 20Vrms for more than 30 seconds.	Check for low voltage at the wall outlet at unit start-up.	Contact a qualified electrician.
Scale	Scaling Factor error - one of the credit peripherals has introduced a scaling factor that is not compatible with the current configuration.	Check the connections of changer harness; make sure changer is plugged in and working.	Make corrections to harness or replace the changer if necessary.
Inlet Sensor	Machine's coin inlet sensor is blocked for more than 1 minute.	Check changer harnessing for cut, pinched or crimped wires.	Replace harnesses or changer.
Inlet block	3 successive coins are detected at the inlet but do not make it into the changer in 10 seconds.	Check inlet for blockage. If nothing is found, check changer harnessing for cut, pinched or crimped wires.	Clear blockage or replace harness or changer.
<b>ERROR</b>	<b>PROBABLE CAUSE</b>	<b>CORRECTIVE ACTION</b>	
<b>Coin Acceptance/Payout (Record all errors for reference if SandenVendo America, Inc. Technical Service is required)</b>			
Coin mechanism will not accept coins.	No power to control board.	Check to make sure the red LED on the control board is flashing red. If flashing, check MDB harness connections. If connections are good, replace changer.	
	Harness from coin mech to board is cut or disconnected.	Use a meter and check each wire for continuity and ground.	
	Short in coin mechanism.	Replace coin change/acceptor	
	Accepter is dirty or other problem may exist (not tuned).	Clean acceptor or contact your local coin mech dealer.	
	Defective control board.	Replace control board.	
No acceptance or rejects a percentage of good coins.	Coin return lever pressing down on acceptor's coin plunger.	Make sure changer is mounted correctly and the coin return lever is in the proper position.	
	Accepter is dirty or foreign matter is in the path.	Clean acceptor or contact dealer.	
	Coin changer is improperly tuned (if tunable).	Contact manufacturer for tuning.	
	Defective controller board.	Replace/test controller.	



## Accessing Error Codes Using Diagnostics Mode (Continued)

Always accepts coins but gives erratic/no credit.	If NO CREDIT: Defective harness between coin mech and control board (will have "Changer Communication" error).	Check harness for cut wires or wrong/bad connections. Test each wire for continuity or test to ground. If found to be defective, replace.
	If ERRATIC OR NO CREDIT: Acceptor or coin mech.	Replace coin mech and test.
	If NO CREDIT: Defective controller.	Replace/test controller.
Changer will not payout coins.	Defective harness between coin mech and control board.	Test vendor's manual coin payout. If vendor won't pay out using the CPO mode or during sales, check harness for cuts, bad continuity or wrong connections. If defective, replace and test.
	Defective coin mech.	Replace coin mech and test.
	Defective controller board.	If coin mech won't payout coins manually in the Change Pay Out mode or during the Sales Mode and the above two procedures have failed, replace the control board and test payout both in the Change Pay Out mode and during a sale.
	Changer payout buttons are disabled while door is closed or while in Open-Door Sales Mode	Enter the Service Mode or access the Coin Payout Mode ("Change Pay Out").
<b>BILL ACCEPTANCE</b>		
Bill Acceptor will not pull bill in.	No power to validator.	Unplug service cord. Wait for 10 seconds. Plug in service cord and see if bill acceptor cycles. If not, check acceptor harnessing or replace the bill acceptor.
	Acceptance disabled by coin mech (if present), or bad harnessing.	Make sure that the coin mech is plugged in (accepts coins) and that the coin tubes have enough coins to enable bill acceptance.
	Coin mech is not operative.	Make sure that the changer harnessing is correctly connected and has continuity. Repair or replace if necessary.
	Replace acceptor and test.	If acceptor accepts, bill acceptor was defective.
Bill acceptor takes a bill but does not establish credit.	Defective acceptor harness (credit not getting from acceptor to control board through the harness).	Make sure that the acceptor and harnessing is correct for your style of acceptor and it is plugged in and wired properly.
	Defective acceptor.	Replace/test acceptor.
	Defective controller.	Replace/test controller.
Bill acceptor takes a bill and credits but not erasing credit.	Defective bill acceptor.	Replace acceptor and test acceptance and erasure of credit.
	Defective controller.	Replace/test controller for erasure of credit.
	Both vend sensors are defective.	Replace vend sensor.
Acceptor takes a bill and allows payback of coins without a selection.	Controllers configurations not set properly	access vendor configuration mode and check the "Forced Vend" setting.



## Accessing Error Codes Using Diagnostics Mode (Continued)

VENDING PROBLEMS		
Multiple vending (not canceling credit).	If multiple vending is from all selections, delivery sensor is out, improperly grounded, or defective.	Test vend sensor (green light on control board when the chute is hit). Replace sensors and test.
	NOTE: If both sensors are not present or are defective, the V21 will allow up to four products from each column to be vended before the column is determined to be sold out.	Replace sensors and test.
	Depth setting on partition not adjusted correctly.	Move can clip to proper position (refer to loading diagram on machine).
	Mechanical Error.	check for correct operation of the motor, lock link, bucket and gate.
Wrong product vended upon selection.	Misload by vendor loader.	Ensure that all product within each column is the same.
	Space-to sales not set properly.	Look for Space to Sales error. Check or reset Space-to-sales.
	Miswired selection.	Check the wiring from the controller to the selection switches. Test selection switches
No vend upon selection.	Delivery sensor is malfunctioning or a column is jammed or sold out.	Check to see if the delivery chute sensor LED is constantly on. If so, replace vend sensor.
	Defective controller board.	Unplug the sensors connection from the control board. Watch LED. IF the sensor LED stays on, replace the defective controller.
Dry Vend (No refund).	Premature vend detection.	Tap on chute and check for a green flashing light on the control board. If no light is flashing or light is on constantly on, replace sensors.
Completely sold out.	Check to see if blocking is enabled.	Change time or turn off blocking.
	Check if vend sensor is unplugged.	Plug back in.
	Space to sales has been cleared.	Reinitiate space to sales.
MISCELLANEOUS PROBLEMS		
Display shows sold out immediately upon pressing selection button of full column (sold out not clearing).	Door switch wired incorrectly or cut/pinched.	Manually press door switch. If lights don't come on, check wiring or replace door switch.
	Control board.	If door switch is replaced and still reading sold out, replace control board.
Vendor appears dead; no digital display and no lights.	Defective main harness. Secondary power harness to the transformer.	Check transformer and fuse.
	Control Board LED	Check power to control board. If there is power check LED. If LED is not lit or is solid red, replace the control board.





## Accessing Error Codes Using Diagnostics Mode (Continued)

No digital display; vendor lights on.	Defective display or display harness.	Check display and display harness. Replace if necessary.
	Check for a flashing red light on control board.	If no light, replace control board.
	Defective MDB harness.	Replace MDB harness.
Vendor scrolls message on display but does not accept money.	Changer out of tune.	See "Tuning Changer".
	Defective changer.	Replace changer.
	Defective controller board.	Replace control board.
Vendor accepts money but does not credit.	Defective changer.	replace changer.
	Defective controller board.	Replace board.
Vendor accepts and credits money but does not vend (does not indicate a sold-out).	Defective selection switch.	Replace switch.
	Defective selection switch harness.	Repair or replace harness.
	Defective controller board.	Replace board.
Vendor delivers wrong product.	Vendor loaded wrong.	Correct loading.
	Vendor space-to-sales set wrong.	See "Space to Sales"
	Defective control board.	Replace board.
Display not functioning correctly or dead.	Check connection.	Replace display and/or harness.
<b>Refrigeration</b>		
Refrigeration unit will not run.	Defective temperature sensor.	1. Check connection. 2. Replace temperature sensor.
	Defective control board.	Replace board.
Refrigeration unit will not run at all.	No power to vendor.	Check power supply, also check service cord connections.
Unit will only run in the compressor relay test mode. (Located under Test).	Defective door switch.	Open and close the door to make sure lights come on. If not, then check the door switch.
	Defective temperature sensor.	Follow the same steps detailed above about the temperature sensor.
	Wait the 3 minute delay once the door is closed.	Wait to see if unit comes on.
	Defective control board.	If unit still does not come on, then replace the control board.
Unit will not run in the compressor relay test mode. <b>**NOTE:</b> Leave the compressor relay test mode on, in order to check for voltage.	Defective control board.	Remove air dam and check 3-pin connection on power board for 110V at pins 1 & 3. Turn compressor on in test mode. (See flow chart if 110V exists).
	Defective relay.	Upon opening the door, the lights and compressor should shut off. If they don't, replace the door switch.
Refrigeration unit runs constantly.	Defective door switch.	Upon opening the door, the display should not read "Hello Welcome...". If it does, then replace the door switch.
	Defective control board.	Replace control board.
	Defective relay - contacts are welded together.	Replace power board.



## Accessing Error Codes Using Diagnostics Mode (Continued)

Compressor will not start.	Overload protector inoperative.	Check overload.(apply insulated jumper across terminal, if compressor starts replace overload protector.
	Defective door switch.	Check for error codes. Replace door switch.
Compressor will not start, condenser fan motor running - unit hot (power to compressor).	Starting relay or capacitor inoperative.	Replace starting relay or capacitor.
	Compressor inoperative.	Disconnect power to vender, remove all leads from compressor, check continuity from "common", "start" and "run" to compressor case. If shows continuity, replace compressor (windings shorted). Also check from common to start, verify that continuity exist between both terminals.
Compressor starts but does not run.	Will not cycle.	Check overload and contacts. Replace if needed. Replace Start relay. Check, replace if needed.
	Starting relay stays closed.	
	Compressor motor problem.	
Compressor runs but cabinet temperature warm.	Loss of refrigerant.	Replace refrigeration unit, contact SandenVendo America, Inc. Technical for warranty service. Check for obstruction of fan blades check curcuit to fan motor, replace. Clean lint and dirt from condenser fins. Check for obstruction of evaporator fan blades, check curcuit for fan motor, replace. Check for moisture on seal adjust inner door as needed. Replace.
	Condenser fan not working.	
	Blocked or dirty condenser (refer to initial installation in the service manual).	
	Evaporator fan not working.	
	Bad inner door seal.	
Both compressor and condenser fan motors will not operate.	Bad refrigeration control relay.	Test relay with relay test function of the control board, replace relay. Check wiring connections
	Bad connection at power board.	
Evaporator frosted over.	Water at base of evaporator unit.	Check for proper drainage (such as plugged drain, kinks in drain tube, etc.). Check door seal.
	Defective control board.	Replace control board.
	Evaporator motor.	Verify 120 Volts exists to evaporator motors.
	Defective evaporator motor.	Replace motor.
Product freezing up (too cold).	Temperature setting too low.	Adjust temperature setting in electronic controller.
	Defective temperature sensor.	Replace Temperature sensor.
Excessive noise.	Fan blade hitting shroud.	Relocate shroud position.
	Fan motor noisy.	Replace if necessary.
	Refrigeration base loose or bent.	Tighten bolt or replace if necessary.



NOTES